



Organisation Mondiale de la Santé Animale

World Organisation for Animal Health

Organización Mundial de Sanidad Animal

Original: English  
September/October 2009

## REPORT OF THE MEETING OF THE OIE AQUATIC ANIMAL HEALTH STANDARDS COMMISSION

Paris, 28 September–2 October 2009

The OIE Aquatic Animal Health Standards Commission (the *Aquatic Animals Commission*) met at the OIE Headquarters from 28 September to 2 October 2009.

Details of participants and the adopted agenda are given at [Annexes I and II](#).

The Aquatic Animals Commission recognised the contribution of the following Members in providing comments: Australia, Canada, Chinese Taipei, European Union (EU), Switzerland, Thailand and the United States of America (USA).

The Aquatic Animals Commission reviewed various OIE *Aquatic Animal Health Code* (the *Aquatic Code*) draft texts from its March 2009 report in the light of Member comments. The outcome of the Commission's work is presented at [Annexes III to XXVII](#) in this report. Amendments made during the March 2009 meeting are shown as double underlined text, with deleted text in ~~strikeout~~, while those made at this meeting (September 2009) are shown in a similar fashion but with a coloured background to distinguish the two groups of proposals.

The table below summarises the texts presented in the Annexes. Part I: [Annexes III to XXIII](#) will be proposed for adoption at the 78<sup>th</sup> OIE General Session in May 2010; Part II: [Annexes XXIV to XXVII](#) are presented for Members' information.

The Aquatic Animals Commission strongly encourages Members to participate in the development of the OIE's international standards by submitting comments on this report. It would be very helpful if comments were submitted as specific proposed text changes, supported by a scientific rationale. Proposed deletions should be indicated in ~~strikeout~~ and proposed additions with double underline. Members **should not use the automatic 'track-change' function** provided by word processing software as such changes are lost in the process of collating Members' submissions into the Commission's working documents.

Comments on this report must reach OIE Headquarters by **22 January 2010** to be considered at the 22–26 February 2010 meeting of the Aquatic Animals Commission. Comments should be sent to the International Trade Department at: [trade.dept@oie.int](mailto:trade.dept@oie.int).

<b>Part I: Texts proposed for adoption</b>	<b>Annex number</b>
Glossary	Annex III
Diseases listed by the OIE (Ch. 1.3.)	Annex IV
Example Article X.X.3.; X.X.9.; X.X.12.	Annex V
Amended text for epizootic haematopoietic necrosis (Articles 10.1.3., 10.1.9., 10.1.12.), Taura syndrome (Articles 9.4.3., 9.4.9., 9.4.11.) and for infection with <i>Bonamia ostreae</i> (Articles 11.2.3., 11.2.9., 11.2.11.)	Annex VI
Criteria to assess the safety of aquatic animal commodities (Ch 5.3.)	Annex VII
Measures concerning international transport of aquatic animal disease agents and pathological material (Ch 5.9.)	Annex VIII
Import Risk Analysis (Ch 2.2.)	Annex IX
Quality and Evaluation of Competent Authorities (Ch 3.1.)	Annex X
Application of compartmentalisation (Ch 4.X.)	Annex XI
Zoning and compartmentalisation (Ch 4.1.)	Annex XII
Control of aquatic animal health hazards in aquatic animal feed (Ch 4.5.)	Annex XIII
General obligations related to certification (Ch. 5.1.)	Annex XIV
Certification procedures (Ch. 5.2.)	Annex XV
Model international aquatic animal health certificates (Ch 5.10.)	Annex XVI
Welfare of farmed fish during transport (Ch 7.2.)	Annex XVII
Article X.X.8 for all disease specific chapters	Annex XVIII
Infection with abalone herpes-like virus (Ch 11.X.)	Annex XIX
Necrotising hepatopancreatitis (Ch 9.X.)	Annex XX
Disinfection of salmonid eggs – (Article 10.4.X., Article 10.5.X., Article 10.9.X.)	Annex XXI
Slaughter of farmed fish for human consumption (Ch 7.3.)	Annex XXII
Introduction to the recommendations for controlling antimicrobial resistance (Ch 6.1.)	Annex XXIII
<b>Part II: Annexes for Members' information</b>	<b>Annex number</b>
Guidance on considering species as susceptible to a disease	Annex XXIV
Report of the <i>ad hoc</i> Group on the Safety of Commodities derived from Aquatic Animals (August 2009)	Annex XXV
Report of the <i>ad hoc</i> Group on Crustacean Diseases – electronic meeting (July – Sept 2009)	Annex XXVI
Aquatic Animals Commission Work Plan 2009/1010	Annex XXVII

## Meeting with Dr Vallat

Dr Bernard Vallat, Director General of the OIE, joined the Commission for a short discussion and warmly welcomed both the returning and new members of the Commission. Dr Vallat indicated that the management and reporting of diseases, particularly in regard to emerging diseases and diseases at the interface between animal and human ecosystems, are priority areas for international organisations and OIE Members, and that this would be reflected in the OIE fifth Strategic Plan (2011–2016). As aquaculture makes an important contribution to the global struggle against hunger, it would be important for the Commission to further strengthen its standard setting activities and for members of the Commission to participate with the OIE Regional Commissions and Regional Representations to ensure that OIE Members are aware of and apply the provisions of the *Aquatic Code*.

Turning specifically to the draft OIE fifth Strategic Plan (2011–2016), Dr Vallat mentioned the proposal to establish a new Scientific Commission for Aquatic Animal Diseases. In subsequent discussion, the President, Dr Barry Hill, and Dr Vallat agreed that there did not seem to be a strong rationale to support this proposal at the present time, as the scientific work of the Aquatic Animals Commission was proceeding well and the membership had been augmented with a sixth person by decision of OIE Delegates in May 2009. In view of the significant resource implications of creating a new Commission, there was general agreement from the Aquatic Animals Commission that this development was not warranted, the final decision being taken by the World Assembly of Delegates.

Dr Vallat reminded the Commission that the expansion of its mandate to cover animal production food safety and animal welfare were important decisions of Delegates at the May 2009 General Assembly and encouraged the Commission to pursue this work actively. Dr Vallat considered that the development of recommendations on the management of resistance to antibacterial products in aquatic animals and the finalisation of the *Aquatic Code* text on Feed for Aquatic Animals were particular priorities. He also encouraged the Commission to liaise with the OIE Animal Production Food Safety Working Group (APFSWG), which will hold its next meeting on 3–5 November 2009, and provide input to the APFSWG's discussion paper on future standard setting priorities in animal production food safety. In light of the great importance of aquaculture and aquatic animal health to food production, foodborne illness associated with aquatic animals during production should be addressed by the OIE.

Dr Vallat noted that the Commission is continuing to develop text for the *Aquatic Code* on the welfare of farmed fish and encouraged the Commission to propose text that is reasonably generic and flexible, so that all OIE Members could apply the provisions in practice.

Finally, Dr Vallat identified some important developments within the OIE disease surveillance and reporting provisions as these apply to wildlife and noted that this was entirely consistent with the longstanding approach of the Aquatic Animals Commission.

## 1. Activities and progress of *ad hoc* Groups

### 1.1. Report of the *ad hoc* Group on Safety of Commodities Derived from Aquatic Animals – August 2009

Dr Franck Berthe, Chair of the *ad hoc* Group, gave a summary of progress made at the meeting held from 24 to 26 August 2009 at the OIE Headquarters (Paris). Dr Berthe reported that the *ad hoc* Group considered Member comments on the 'example articles' to be included in all disease specific chapters, and to Article 5.9.1. entitled 'Measures concerning the international transport of aquatic animal disease agents and pathological material' and made relevant amendments. Details are provided under Agenda Item 2.4. and 2.7., respectively.

The *ad hoc* Group undertook an assessment of commodities listed for a fish disease (epizootic haematopoietic necrosis), a crustacean disease (Taura syndrome) and a mollusc disease (infection with *Bonamia ostreae*). Commodities currently listed in Article X.X.3. point 1a) were assessed using criteria in Article 5.3.1., and commodities currently listed in Article X.X.3. point 1b) were assessed using criteria in Article 5.3.2. for these three diseases. Detail is provided under Agenda Item 2.6.

The *ad hoc* Group also developed a draft new article on trade measures for disinfected salmonid eggs for three disease chapters: viral haemorrhagic septicaemia, infectious salmon anaemia and infectious haematopoietic necrosis. Detail is provided under Agenda Item 3.3.

Dr Hill thanked Dr Bethe and the *ad hoc* Group for their very comprehensive work on this complex subject. The Aquatic Animals Commission recommended that the *ad hoc* Group be reconvened at a suitable time to continue their work and complete a report prior to the next Commission meeting in February 2010.

The *ad hoc* Group report is provided for information at [Annex XXV](#).

## **1.2. Report of the *ad hoc* Group on Crustacean Diseases – electronic meeting (July – Sept 2009)**

Dr Don Lightner, Chair of the *ad hoc* Group, gave a summary of progress made from the electronic meeting held from July to September 2009. Dr Lightner reported that the *ad hoc* Group re-assessed necrotising hepatopancreatitis disease against the criteria for listing aquatic animal diseases in the *Aquatic Code* (Article 1.2.1.), taking into account a Member's comment. Detail is provided under Agenda Item 2.3.

Dr Hill thanked Dr Lightner and the *ad hoc* Group for their work undertaken promptly in response to the request from the Aquatic Animals Commission.

The *ad hoc* Group report is provided for information at [Annex XXVI](#).

## **2. OIE Aquatic Animal Health Code: amendments to existing chapters**

### **2.1. General comments**

The Aquatic Animals Commission agreed that it is important to continue to harmonize the *Aquatic* and *Terrestrial Codes* but recognized there are inherent differences in some areas where harmonization is not feasible. To facilitate the process of review and harmonization, the Commission encouraged Members to ensure that their comments on relevant horizontal text are submitted to both the Code and Aquatic Animals Commissions.

### **2.2. Glossary**

The Aquatic Animals Commission reviewed the *Aquatic Code* Glossary and made a number of amendments.

The following definitions were amongst those amended, to be consistent with the equivalent definitions in the *Terrestrial Code*, as part of the ongoing harmonisation of the two Codes:

Protection zone, Competent Authority, Emerging disease, Feed additives, Hazard, International aquatic animal health certificate, Pathological material and Veterinary Services.

*Personnel of the Competent Authority* was deleted as it is not used in the *Aquatic Code* and *slaughtering* was deleted as it is only used once in the *Aquatic Code*.

The revised chapter is provided at [Annex III](#) for Member comments.

### **2.3. Diseases listed by the OIE (Chapter 1.3.)**

The *ad hoc* Group on the OIE List of Aquatic Animal Diseases (Crustacean Team) considered a Member's proposal that necrotising hepatopancreatitis (NHP) be de-listed. The *ad hoc* Group disagreed with the proposal and recommended that NHP, currently listed under study, be listed as an OIE disease. Full justification is provided in the Crustacean *ad hoc* Group Report ([Annex XXVI](#)).

The Aquatic Animals Commission endorsed the Crustacean *ad hoc* Group recommendation to list necrotising hepatopancreatitis.

The revised chapter is provided at [Annex IV](#) for Member comments.

### **2.4. Example Article X.X.3; X.X.9; X.X.12.**

The Aquatic Animals Commission considered the recommendations of the *ad hoc* Group on Safety of Commodities Derived from Aquatic Animals in response to Member comments on the 'example articles' to be included in all disease specific chapters and made some minor amendments. This draft text is presented as clean text for ease of readability. The tracked version is available in the *ad hoc* Group report in [Annex XXV](#).

The amended Articles are provided at [Annex V](#) for Member comments.

### **2.5. Amended text for epizootic haematopoietic necrosis (Articles 10.1.3., 10.1.9. and 10.1.12.), Taura syndrome (Articles 9.4.3., 9.4.9. and 9.4.11.) and for infection with *Bonamia ostreae* (Articles 11.2.3., 11.2.9. and 11.2.11.)**

The Aquatic Animals Commission reviewed the text proposed by the *ad hoc* Group on Safety of Commodities Derived from Aquatic Animals for amendments of epizootic haematopoietic necrosis (Articles 10.1.3., 10.1.9. and 10.1.12.), Taura syndrome (Articles 9.4.3., 9.4.9. and 9.4.11.) and for infection with *Bonamia ostreae* (Articles 11.2.3., 11.2.9. and 11.2.11.). These amendments are based on proposed draft 'Disease X' Articles X.X.3.; X.X.9.; X.X.12. and specific assessments of commodities currently listed in Article X.X.3.

In these Articles, reference to the assessments undertaken by the *ad hoc* Group is provided as a footnote indicating where to find these assessments in the *ad hoc* Group report. The Aquatic Animals Commission welcomes Member comments on these assessments.

The revised articles are provided at [Annex VI](#) for Member comments.

## **2.6. Criteria to assess the safety of aquatic animal commodities (Chapter 5.3.)**

The Aquatic Animals Commission noted that in the process of conducting the commodity assessments (see Item 2.1.2.) the *ad hoc* Group on Safety of Commodities Derived from Aquatic Animals made amendments to the text of Article 5.3.1. and Article 5.3.2. The Aquatic Animals Commission agreed with the proposed amendments.

The revised chapters are provided at [Annex VII](#) for Member comments.

## **2.7. Measures concerning international transport of aquatic animal disease agents and pathological material (Chapter 5.9.)**

In their report to the Aquatic Animals Commission ([Annex XXV](#)), the *ad hoc* Group on the Safety of Commodities Derived from Aquatic Animals considered Member comments on the proposed text for Article 5.9.1. in the *Aquatic Code* to address the issue of biological samples preserved for diagnostic applications.

The revised article is provided at [Annex VIII](#) for Member comments.

## **2.8. Import risk analysis (Chapter 2.2.)**

The Aquatic Animals Commission considered the proposed amendments to the corresponding chapter in the *Terrestrial Code* and amended the text as appropriate for the chapter on import risk analysis (Chapter 2.2.), as part of the ongoing harmonisation of the two *Codes*.

The revised chapter is provided at [Annex IX](#) for Member comments.

## **2.9. Quality and evaluation of Competent Authorities (Chapter 3.1.)**

The Aquatic Animals Commission considered the proposed amendments to the corresponding chapter in the *Terrestrial Code* and amended the text as appropriate for the Chapter on Quality and Evaluation of Competent Authorities (Chapter 3.1.), as part of the ongoing harmonisation of the two *Codes*.

The revised chapter is provided at [Annex X](#) for Member comments

## **2.10. Zoning and compartmentalisation (Chapter 4.1.)**

The EU and Norway had previously commented on the absence of options for regaining freedom for previously-free compartments after the detection of the disease in all disease specific chapters.

The Aquatic Animals Commission considered preparing general text for all disease chapters but concluded that the conditions for restoring disease free status for a compartment needed to be disease specific and take into account the different characteristics/factors for the different diseases. This task will require a significant amount of time and effort and it was not possible for the Aquatic Animals Commission to undertake this work during this meeting. Given the size of the task, the Aquatic Animals Commission considered this work would need to be prioritised in order to determine which specific disease to address first.

The Aquatic Animals Commission reviewed the texts on compartmentalisation in the *Aquatic* and *Terrestrial Codes* and noted that the *Terrestrial Code* included a specific chapter on the application of compartmentalisation (Chapter 4.4.). The Aquatic Animals Commission agreed that similar text should be included in the *Aquatic Code*.

The Aquatic Animals Commission drafted a chapter on application of compartmentalisation (Chapter 4.X.).

The new draft chapter is provided in [Annex XI](#) for Member comments.

The Aquatic Animals Commission also amended Chapter 4.1. by removing provisions specific to compartmentalisation as these are now included in the draft chapter 4.X.

The revised chapter is provided in [Annex XII](#) for Member comments.

### **2.11. Control of aquatic animal health hazards in aquatic animal feed (Chapter 4.5.)**

The Commission noted the advice of the OIE International Trade Department that relatively few modifications were needed to Chapter 4.5., which had been adopted at the 77<sup>th</sup> General Session in May 2009, to address the expanded mandate of the Commission to include food safety. The chapter had originally been drafted along appropriate lines and needed only minor modification to explicitly address animal production food safety. The Commission made some small modifications to the text.

The revised chapter is provided in [Annex XIII](#) for Member comments.

### **2.12. General obligations related to certification (Chapter 5.1.)**

The Aquatic Animals Commission considered a Member comment and the proposed amendments to the corresponding chapter in the *Terrestrial Code* and amended the text as appropriate for the chapter on general obligations related to certification (Chapter 5.1.), as part of the ongoing harmonisation of the two *Codes*.

The revised chapter is provided at [Annex XIV](#) for Member comments.

### **2.13. Certification procedures (Chapter 5.2.)**

The Aquatic Animals Commission considered the proposed amendments to the corresponding chapter in the *Terrestrial Code* and amended the text as appropriate for the chapter on certification procedures (Chapter 5.2.), as part of the ongoing harmonisation of the two *Codes*.

The revised chapter is provided at [Annex XV](#) for Member comments.

### **2.14. Model international aquatic animal health certificates (Chapter 5.10.)**

The Aquatic Animals Commission considered a Member's comment on the chapter on model international aquatic animal health certificates (Chapter 5.10.) and amended the text accordingly.

The revised chapter is provided at [Annex XVI](#) for Member comments.

### 2.15. Welfare of farmed fish during transport (Chapter 7.2.)

The Aquatic Animals Commission reviewed the text under study in Article 7.2.3. '[Except for disease control purposes]' and amended the text as follows:

The ability of the fish to cope with the stress of transport should be assessed based on health status, previous handling and recent transport history of the fish. Generally, only fish that are fit for transport should be loaded. ~~Except for Transport for~~ disease control purposes, should be in accordance with Chapter X.X. on the humane killing of fish for disease control purposes (in preparation); (under study)] Only fish that are fit for transport should be loaded.

The Aquatic Animals Commission amended the title of this chapter to be consistent with the corresponding chapter in the *Terrestrial Code*.

The revised chapter is provided at [Annex XVII](#) for Member comments.

### 2.16. References to non-susceptible species in mollusc chapters

The Aquatic Animals Commission agreed with the recommendation of the *ad hoc* Group on Safety of Commodities Derived from Aquatic Animals that the reference to non-susceptible species in Article X.X.3. point 1c) of the *Aquatic Code* chapters on Infection with *Bonamia ostreae*, *Martellia refringens* and *B. exitiosa* be moved to the relevant OIE *Manual of Diagnostic Tests for Aquatic Animals* chapters and requested that the OIE Scientific and Technical Department undertake this task.

### 2.17. Invasive alien species

Dr Sarah Kahn briefed the Commission on the preparation of a special edition of the OIE *Scientific and Technical Review* on Invasive Alien Species. The Commission recalled that in 2007 the OIE had adopted references to the Code of Practice on the Introduction and Transfers of Marine Organisms of the International Council for the Exploration of the Seas (ICES) and that these appear in all disease specific chapters in Article X.X.8.

The ICES Code of Practice sets forth recommended procedures and practices to diminish the risks of detrimental effects from the intentional introduction and transfer of marine (including brackish water) organisms.

The Commission reviewed Article X.X.8., for all disease specific chapters, and made some modifications to clarify that the recommendation in the *Aquatic Code* for OIE Members to apply the provisions of the ICES Code are limited to issues under the OIE mandate and do not extend to the specific ICES provisions for the assessment of invasiveness when establishing measures for the translocation of aquatic animals.

The revised Article X.X.8. for inclusion in all disease specific chapters is provided in [Annex XVIII](#) for Member comments.

## 3. OIE *Aquatic Animal Health Code*: proposed new articles and chapters

### 3.1. Infection with abalone herpes-like virus (Chapter 11.X.)

The Aquatic Animals Commission considered Member comments on the draft chapter on abalone herpes-like virus and amended the text accordingly.



Several Members commented on Article X.X.1. regarding the inclusion of ‘associated manifestations’ in the definition of infection with abalone herpes-like virus. The Aquatic Animals Commission agreed that this definition reflected previous case definitions for abalone viral mortality complex (AVM) and amended the text as shown below:

‘For the purposes of the *Aquatic Code*, infection with abalone herpes-like virus means ~~herpes-like virus associated manifestation in abalone~~, any form of the abalone viral mortality complex (AVM) caused by abalone herpes-like virus.’

The revised chapter is provided in Annex XIX for Member comments.

### 3.2. Necrotising hepatopancreatitis (Chapter 9.X.)

The Crustacean *ad hoc* Group had previously prepared a draft disease chapter for necrotising hepatopancreatitis (NHP) which the Aquatic Animals Commission circulated to Members for comment as part of their October 2008 Report. The Crustacean *ad hoc* Group considered Member comments on that draft chapter and amended the text accordingly during the meeting of the *ad hoc* Group held in June 2008 (see June 2008 Crustacean *ad hoc* Group report for details).

The Aquatic Animals Commission endorsed the draft chapter that will be proposed for adoption at the 78<sup>th</sup> General Session in May 2010 provided the World Assembly of Delegates adopts the listing of this disease.

The new draft chapter is provided at Annex XX for Member comments.

### 3.3. Disinfection of salmonid eggs – (new Articles: Article 10.4.X., Article 10.5.X., Article 10.9.X.)

In their report to the Aquatic Animals Commission, the *ad hoc* Group on the Safety of Commodities Derived from Aquatic Animals developed a draft new article on trade measures for disinfected salmonid eggs for three disease chapters: viral haemorrhagic septicaemia, infectious salmon anaemia and infectious haematopoietic necrosis (see Item 1.1.). In the case of EHNV there is lack of published information regarding vertical transmission and the *ad hoc* Group recommended that a formal request for further information be addressed to the OIE Reference Laboratories for EHNV. The Aquatic Animals Commission requested that OIE Headquarters seek this information from the Reference Laboratories.

The Aquatic Animals Commission reviewed the *ad hoc* Group’s draft text and made some minor amendments.

The new draft Articles are provided at Annex XXI for Member comments.

### 3.4. New chapter – slaughter of farmed fish for human consumption (Chapter 7.3.)

The Aquatic Animals Commission developed a draft chapter on the slaughter of farmed fish for human consumption. These recommendations apply to the slaughter of farmed fish species for human consumption and address the need to ensure the welfare of farmed fish intended for human consumption, during pre-slaughter and slaughter processes, until they are dead. The draft chapter describes general principles that should be applied to ensure the welfare of fish for slaughter and also applies to fish killed for disease control purposes and intended for human consumption. Specific measures applicable to emergency killing for disease control purposes not intended for human consumption will be addressed in Chapter 7.4. entitled “Humane killing of fish for disease control purposes (under development)”.

The Commission discussed the use of anaesthetics to sedate fish prior to killing. In Australia, New Zealand and Chile, isoeugenol (e.g. active ingredient in AQUI-S™) is authorised for stunning in combination with exsanguination for slaughter of fish. The welfare aspects of pharmaceutical methods have been recently assessed (EFSA, 2009) and stress mechanisms in relation to isoeugenol are described in Zahl *et al.* (2009). The Commission also considered the recent classification of isoeugenol by the U.S. National Toxicology Program as a carcinogen in male mice (Meinertz and Schreier, 2009), and uncertainty regarding the possible use of this product as an immediate-release sedative. The Commission agreed that more information on the food safety aspects of the isoeugenol method is needed before it can be included in the chapter on slaughter of farmed fish for human consumption.

The Commission also agreed that pharmaceutical methods used for humane killing of fish that are not intended for human consumption would be considered for inclusion in Chapter 7.4. entitled “Humane killing of fish for disease control purposes (under development)”.

#### References:

EFSA (2009). Scientific Opinion of the Panel on Animal Health and Welfare on a request from the European Commission on welfare aspect of the main systems of stunning and killing of farmed Atlantic salmon. *The EFSA Journal* (2009) 1012, 1–77.

MEINERTZ J.R. AND SCHREIER T.M. (2009). Depletion of isoeugenol residues from the fillet tissue of AQUI-S™ exposed rainbow trout (*Oncorhynchus mykiss*). *Aquaculture*, 296:200–206.

ZAHN I.H., KIESSLING A.K., SAMUELSEN O.B. AND OLSEN R.E. (2009). Anaesthesia induces stress in Atlantic salmon (*Salmo salar*), Atlantic cod (*Gadus morhua*) and Atlantic halibut (*Hippoglossus hippoglossus*). *Fish Physiology and Biochemistry*. On line: <http://www.springerlink.com/content/22785776gkk51778/>

The new draft chapter is provided in Annex XXII for Member comments.

## 4. OIE Aquatic Animal Health Code: other items

### 4.1. Guidance on considering species as susceptible to a disease

At its March 2009 meeting, the Aquatic Animals Commission had discussed Member requests for clarification about the basis for deciding whether single or multiple species or entire families should be considered as susceptible to diseases. The Commission further discussed this issue and agreed that a conservative approach should be taken to this question. Where there was evidence supporting the susceptibility of multiple species, and little/no evidence suggesting that species in the same genus, family or order were resistant to infection, the Commission would assume that all species in the genus, family or order were susceptible, pending scientific findings to the contrary.

Related to this matter, the Commission agreed on the need to develop guidance for experts to decide which species should be listed as susceptible in Article X.X.2. for all disease specific chapters in the *Aquatic Code* as well as the disease specific chapters in the *Aquatic Manual*.

The Commission developed a short paper for guidance of experts. The Commission noted that application of this guidance could result in some changes to the species currently identified as susceptible in the disease specific chapters in the *Aquatic Code* and *Aquatic Manual*. Therefore, the Commission invited OIE Members to provide comments on the guidance paper, even though the text is not intended for inclusion in the *Aquatic Code*.

This guidance document is provided at [Annex XXIV](#) for Member information.

#### **4.2. Resistance to antimicrobials**

Dr Kahn briefed the Commission on the work underway to address the issue of antimicrobial resistance as this relates to aquatic animals, including arrangements to convene an *ad hoc* group to review relevant information, including the current *Terrestrial Code* chapters, with the objective of developing text for inclusion in the *Aquatic Code*. The Commission reviewed the introductory text (Chapter 6.7. of the *Terrestrial Code*) and discussed the need for the ad hoc Group to also consider the issue of antibiotic treatment of wild caught ornamental fish that are transported from developing countries (mostly) to developed countries for sale. The current *Terrestrial Code* text refers to ‘animal husbandry’ and would exclude consideration of this practice. Nonetheless, the Commission felt that the introductory text was generally relevant to aquatic animals.

Accordingly, the Commission made some modifications to the *Terrestrial Code* text (including removing the word ‘husbandry’) for consistency with other chapters in the *Aquatic Code*.

The new draft chapter giving an introduction to the recommendations for controlling antimicrobial resistance (Chapter 6.1.) is provided in [Annex XXIII](#) for Member comments.

#### **4.3. OIE Evaluation of Performance of Veterinary Services and other Competent Authorities**

Dr Kahn updated the Aquatic Animals Commission on developments with PVS, including the organisation of a workshop on experience in the use of the OIE *PVS Tool* (9–10 December 2009), to be followed by a meeting of the *ad hoc* Group on the Evaluation of Veterinary Services (11 December 2009), at which necessary revisions to the *PVS Tool*, including any modifications needed to make it more relevant to Aquatic Animal Health Services, would be discussed. The Commission was pleased to note that a pilot evaluation of Aquatic Animal Health Services of an OIE Member was planned to take place in November 2009. The findings from this mission will be considered by the *ad hoc* Group in preparing the 2009 edition of the OIE *PVS Tool*. The Commission will continue to monitor developments on this issue.

## 5. Joint meeting with the President of the Terrestrial Animal Health Standards Commission

The Aquatic Animals Commission was joined by Dr Alejandro Thiermann, President of the OIE Terrestrial Animal Health Standards Commission (the Code Commission), for a brief meeting. Dr Thiermann updated the Aquatic Animals Commission on the Code Commission's work on communication. He noted that in response to Member comments the Code Commission had agreed to associate the proposed definitions related to communication with the outline of the draft chapter on communication developed by the *ad hoc* Group. The Code Commission had circulated the outline and proposed definitions to Members and invited Members to provide comments, which would be forwarded to the *ad hoc* Group to be taken into account in the further development of the chapter. The Aquatic Animals Commission appreciated the development of recommendations on communication and agreed to adopt a parallel approach in the *Aquatic Code*.

Dr Thiermann provided an update on the Code Commission's work on compartmentalisation and the recently adopted definition for protection zone in the *Terrestrial Code* which incorporates the concepts that were previously included in the buffer zone and surveillance zone. The idea is to broaden the application of measures to protect susceptible sub-populations beyond a strict reference to physical separation and to incorporate other protection measures. The Aquatic Animals Commission agreed to propose adoption of the definition for protection zone in the *Aquatic Code*.

The Aquatic Animals Commission and Dr Thiermann agreed to continue to work together to ensure ongoing harmonisation of the two *Codes*.

## 6. Upcoming OIE Conferences and Meetings

- 10th Conference of the OIE Regional Commission for the Middle East (25–29 October 2009, Doha, Qatar). Dr Karim Ben Jebara to attend.
- 26th Conference of the OIE Regional Commission for Asia, the Far East and Oceania (16–21 November 2009, Shanghai, People's Republic of China). Dr Huang Jie to attend.
- Second International Conference of OIE Reference Laboratories and Collaborating Centres (21–23 June 2010, Paris, France).

The Aquatic Animals Commission noted the upcoming conference and referred to the position paper on 'Pathogen strain differentiation' it had presented at the first international conference held in Florianopolis (Brazil, 2006). The Aquatic Animals Commission agreed that this subject should be a matter for further discussion and suggest it be a specific theme at the second conference and agreed to provide suggestions for other topics and possible speakers to the conference organizers'.

- FAO/OIE Aquatic Biosecurity Framework for Southern Africa: A Scoping Meeting of Regional Fisheries and Veterinary Authorities (13–14 October 2009, Namibia). Dr Mara Gonzalez to attend.
- FAO's global programme for fisheries and aquaculture focusing on country-level assistance (27–30 October 2009, Rome, Italy). Dr Gillian Mylrea to attend.
- OIE regional aquatic animal focal points training workshops.

Dr Kahn updated the Aquatic Animals Commission on the OIE programme to provide OIE training workshops for aquatic animal focal points in all OIE regions over the next 12 to 18 months. The members of the Commission indicated they were happy to participate in these important workshops.

## 7. OIE *Manual of Diagnostic Tests for Aquatic Animals* – Seventh edition 2012

Ms Sara Linnane, Scientific Editor, from the Scientific and Technical Department, joined the meeting for agenda items 7 and 8.

### 7.1. Review of the sixth edition and discussion on improvements

The sixth edition of the *Aquatic Manual* had been published in August and distributed to the Delegates and the OIE experts. The Commission noted that the disease chapter template was quite complex and that some of the information requested was not necessary to the scope and purpose of the *Aquatic Manual*. It was agreed that the *ad hoc* Group on Aquatic Animal Health Surveillance would be asked to review and simplify the template when it next meets in February 2010.

### 7.2. Commission chapters for new listed diseases

#### 7.2.1. Diseases of amphibians

In May 2008, the World Assembly of Delegates adopted two diseases of amphibians for inclusion in Chapter 1.3. of the *Aquatic Code*: Infection with *Batrachochytrium dendrobatidis* and Infection with ranavirus. Two applications for OIE Reference Laboratories for these two diseases had also been adopted by the World Assembly of Delegates of the OIE in May 2009. The experts will be asked to draft *Aquatic Manual* chapters on the two diseases and an introductory chapter on diseases of amphibians, which could be proposed for adoption in May 2010 and, if adopted, included in the web version of the *Aquatic Manual*.

#### 7.2.2. Infection with abalone herpes-like virus

In May 2009, the World Assembly of Delegates adopted Infection with abalone herpes-like virus in Chapter 1.3. of the *Aquatic Code*. It was agreed that Dr Berthe would collaborate with experts on this disease to urgently update the disease card (by the end of November 2009) and then draft an *Aquatic Manual* chapter, which could be reviewed by the Commission at its meeting in February 2010 before being circulated to Members and presented for adoption in May 2010 and, if adopted, included in the web version of the *Aquatic Manual*.

## 8. OIE Reference Laboratories

### 8.1. New applications for Reference Laboratory and Collaborating Centre status

An application had been received from the Atlantic Veterinary College (AVC), Centre for Aquatic Health Science, University of Prince Edward Island, Canada for a Collaborating Centre for Aquatic Epidemiology and Evidence-Based Health Management, and a second application had been received from the National Veterinary Institute, Department for Epidemiology, Sentrum, Norway for a Collaborating Centre for Risk Assessment, Spatial Modelling and Control of Diseases in Farmed Fish.

The Commission advised that the following aspects of these two applications should be clarified: details of the exact services that each Centre would provide to OIE Members, evidence of the benefits of such services to OIE Members, and a description of how these benefits will be provided. Although it is the intention that the two Centres to cooperate and complement each other as their field of specialisation does not completely overlap, a joint designation may be more appropriate. The Commission will formulate its final opinion at its next meeting taking into account additional information submitted.

The Commission noted that Dr Stephen Feist would replace Dr Hill as he is the new contact point for the OIE Collaborating Centre for Information on Aquatic Animal Diseases at the Centre for Environment, Fisheries & Aquaculture Science (Cefas) Weymouth in United Kingdom.

## **8.2. Infection with abalone herpes-like virus**

Following the listing of Infection with abalone herpes-like virus in May 2009, there is now a need for an OIE Reference Laboratory for this disease. The Aquatic Animals Commission encouraged interested Members with expertise to submit applications for OIE Reference Laboratory status through their OIE Delegate.

## **8.3. Twinning proposal between laboratories in Canada and Chile**

The Commission reviewed an application for a twinning project between laboratories for infectious salmon anaemia in Canada and Chile. The Commission supported the application in principle but considered that the scope of the proposed project went beyond that of a twinning project and requested the application be amended to focus more on the normal twinning aspects as provided in the 'Guide to OIE certified Laboratory Twinning Projects'.

## **9. Any other business**

### **9.1. Second Global Conference on Aquatic Animal Health: 'Contribution of Aquatic Animal Health to Global Food Security', provisionally July 2011 in the Asian region**

All members of the Aquatic Animals Commission indicated that they would be happy to participate in the scientific committee and look forward to receive further information on this conference.

### **9.2. Review of the Aquatic Animals Commission's work plan for 2009/10**

The Aquatic Animals Commission reviewed and updated their work plan, which is provided at [Annex XXVII](#) for Members' information.

## **10. Date of the next meeting**

22–26 February 2010.

---

.../Annexes

**MEETING OF THE OIE**  
**AQUATIC ANIMAL HEALTH STANDARDS COMMISSION**  
**Paris, 28 September–2 October 2009**

---

**Adopted agenda**

**Welcome from the Director General**

**1. Activities and progress of *ad hoc* Groups**

- 1.1. Report of the *ad hoc* Group on Safety of Commodities Derived from Aquatic Animals – August 2009
- 1.2. Report of the *ad hoc* Group on Crustacean Diseases – electronic meeting – 2009

**2. OIE *Aquatic Animal Health Code* – amendments to existing chapters**

- 2.1. General comments
- 2.2. Glossary
- 2.3. Diseases listed by the OIE (Chapter 1.3.)
- 2.4. Example Articles X.X.3., X.X.9. and X.X.12.
- 2.5. Criteria to assess the safety of aquatic animal commodities (Chapter 5.3.)
- 2.6. Amended text for epizootic haematopoietic necrosis (Articles 10.1.3., 10.1.9. and 10.1.12.), Taura syndrome (Articles 9.4.3., 9.4.9. and 9.4.11.) and infection with *B. ostreae* (Articles 11.2.3., 11.2.9. and 11.2.11.)
- 2.7. Measures concerning international transport of aquatic animal disease agents and pathological material (Chapter 5.9.)
- 2.8. Import risk analysis (Chapter 2.2.).
- 2.9. Quality and evaluation of Competent Authorities (Chapter 3.1.)

Annex I (contd)

- 2.10. Zoning and compartmentalisation
- 2.11. Control of aquatic animal health hazards in aquatic animal feed (Chapter 4.5.)
- 2.12. General obligations related to certification (Chapter 5.1.)
- 2.13. Certification procedures (Chapter 5.2.)
- 2.14. Model international aquatic animal health certificates (Chapter 5.10.)
- 2.15. Welfare of farmed fish during transport (Chapter 7.2.)
- 2.16. References to non-susceptible species in mollusc chapters
  - 2.1.7. Invasive alien species
- 3. OIE *Aquatic Animal Health Code* – proposed new articles and chapters**
  - 3.1. Infection with abalone herpes-like virus (Chapter 11.X.)
  - 3.2. Necrotising hepatopancreatitis
  - 3.3. Disinfection of salmonid eggs – (Article 10.4.X., Article 10.5.X. and Article 10.9.X.)
  - 3.4. New welfare chapters
- 4. OIE *Aquatic Animal Health Code* – other items**
  - 4.1. Guidance on considering species as susceptible to diseases
  - 4.2. Resistance to antimicrobials
  - 4.3. OIE Evaluation of Performance of Veterinary Services and other Competent Authorities
- 5. Joint meeting with the President of the OIE Terrestrial Animal Health Standards Commission**
- 6. OIE Conferences and Meetings**



**7. OIE Manual of Diagnostic Tests for Aquatic Animals – Seventh edition 2011**

7.1. Review of the sixth edition and discussion on improvements

7.2. Commission chapters for new listed diseases

7.2.1. Diseases of amphibians

7.2.2. Infection with abalone herpes-like virus

**8. OIE Reference Laboratories**

8.1. New applications for Reference Laboratory and Collaborating Centre status

8.2. Infection with abalone herpes-like virus

8.3. Twinning proposal between laboratories in Canada and Chile

**9. Any other business**

9.1. Second Global Conference on Aquatic Animal Health: 'Contribution of Aquatic Animal Health to Global Food Security'

9.2. Review of the Aquatic Animals Commission's work plan for 2009/10

**12. Date of the next meeting**  

---



**MEETING OF THE OIE  
AQUATIC ANIMAL HEALTH STANDARDS COMMISSION**

**Paris, 28 September–2 October 2009**

-----  
**List of participants**

**MEMBERS OF THE COMMISSION**

---

**Dr Barry Hill**

*President*  
CEFAS Weymouth Laboratory  
Barrack Road, The Nothe  
Weymouth, Dorset DT4 8UB  
UNITED KINGDOM  
Tel.: (44-1305) 20.66.25  
Fax: (44-1305) 20.66.01  
E-mail: [b.j.hill@cefasc.co.uk](mailto:b.j.hill@cefasc.co.uk)

**Dr Ricardo Enriquez**

*Vicepresident*  
Patología Animal / Lab. Biotecnología  
& Patología Acuática  
Universidad Austral de Chile  
Casilla 567 - Valdivia  
CHILE  
Tel.: (56-63) 22.11.20  
Fax: (56-63) 21.89.18  
E-mail: [renrique@uach.cl](mailto:renrique@uach.cl)

**Dr Franck Berthe**

*Secretary General*  
Senior Scientific Officer  
European Food Safety Authority  
- EFSA  
Animal Health and Animal  
Welfare unit  
Largo N. Palli 5/A, 43100 Parma  
ITALY  
Tel.: + 39 0521 036 870  
Fax: + 39 0521 036 0870  
Email:  
[Franck.Berthe@efsa.europa.eu](mailto:Franck.Berthe@efsa.europa.eu)

**Dr Olga Haenen**

Central Veterinary Institute (CVI) of  
Wageningen UR  
Cluster General Bacteriology and Fish  
Diseases  
Fish and Shellfish Diseases  
Laboratory,  
P.O. Box 65  
8200 AB Lelystad  
NETHERLANDS  
Tel.: +31 320 238352  
Fax: +31 320 238153  
Email: [Olga.Haenen@wur.nl](mailto:Olga.Haenen@wur.nl)

**Dr Huang Jie**

Virologist  
Senior Researcher, Head of  
Maricultural Organism Diseases  
Control & Molecular Pathology  
Laboratory,  
Yellow Sea Fisheries Research  
Institute,  
Chinese Academy of Fishery Sciences  
106 Nanjing Road  
Qingdao, SD 266071  
PR CHINA  
Tel.: +86-532-5823062  
Mobile: +86-138-05421513  
Fax: +86-532-5811514  
Email: [huangjie@ysfri.ac.cn](mailto:huangjie@ysfri.ac.cn)  
[aqudis@public.qd.sd.cn](mailto:aqudis@public.qd.sd.cn)

**Dr Victor Manuel Vidal**

Centro de Investigación y de  
Estudios Avanzados del Instituto  
Politécnico Nacional  
Carretera Antigua a Progreso  
Km. 6  
Apartado Postal 73 Cordemex  
Mérida,  
Yucatán C.P. 97310  
MÉXICO  
Tel.: +52 99 99 46 94 02  
Fax: +52 99 81 29 17  
Email: [vvidal@mda.cinvestav.mx](mailto:vvidal@mda.cinvestav.mx)

Annex II (contd)**OTHER PARTICIPANTS**

---

**Prof. Donald V. Lightner  
(Crustacean disease expert)**  
Aquaculture Pathology Section,  
Department of Veterinary Science &  
Microbiology,  
University of Arizona, Building 90,  
Room 202,  
Tucson, AZ 85721  
UNITED STATES OF AMERICA  
Tel.: (1-520) 621.84.14  
Fax: (1-520) 621.48.99  
E-mail: [dvl@u.arizona.edu](mailto:dvl@u.arizona.edu)

**Dr Rohana P. Subasinghe**  
Senior Fishery Resources Officer  
(Aquaculture)  
Fisheries Department  
Food and Agriculture Organization of  
the UN  
Viale delle Terme di Caracalla  
00100 Rome  
ITALY  
Tel.: 39 06 570 56473  
Fax: 39 06 570 53020  
E-mail: [Rohana.Subasinghe@fao.org](mailto:Rohana.Subasinghe@fao.org)

**Prof. Eli Katunguka-Rwakishaya**  
Director  
School of Graduate Studies  
Makerere University,  
P.O. Box 7062,  
Kampala  
UGANDA  
Tel.: (256.41) 53.0983  
Mobile: 256 772 754 685  
Fax: (256-41) 533809  
email:  
[erkatunguka@vetmed.mak.ac.ug](mailto:erkatunguka@vetmed.mak.ac.ug)  
[mupgs@muspgs.mak.ac.ug](mailto:mupgs@muspgs.mak.ac.ug)

**OIE HEADQUARTERS**

---

**Dr Bernard Vallat**  
Director General  
OIE  
12, rue de Prony  
75017 Paris  
FRANCE  
Tel.: 33 - (0)1 44 15 18 88  
Fax: 33 - (0)1 42 67 09 87  
E-mail: [oie@oie.int](mailto:oie@oie.int)

**Dr Sarah Kahn**  
Head  
International Trade Department  
OIE  
E-mail: [s.kahn@oie.int](mailto:s.kahn@oie.int)

**Ms Sara Linnane**  
Scientific editor  
Scientific and Technical  
Department  
OIE  
E-mail: [s.linnane@oie.int](mailto:s.linnane@oie.int)

**Dr Gillian Mylrea**  
Chargée de mission  
International Trade Department  
OIE  
E-mail: [g.mylrea@oie.int](mailto:g.mylrea@oie.int)

## GLOSSARY

### **Buffer zone**

~~means a zone established to protect the health status of aquatic animals in a free country or free zone, from those in a country or zone of a different aquatic animal health status, using measures based on the epidemiology of the disease under consideration to prevent spread of the disease agent into a free country or free zone.~~

### **Protection zone**

means a zone established to protect the health status of aquatic animals in a free country or free zone, from those in a country or zone of a different aquatic animal health status, using measures based on the epidemiology of the disease under consideration to prevent spread of the causative pathogenic agent into a free country or free zone. These measures may include, but are not limited to, vaccination, movement control and an intensified degree of surveillance.

### **Central Bureau/Headquarters**

means the Permanent Secretariat of the World Organisation for Animal Health ~~which headquarters are located at:~~

12, rue de Prony, 75017 Paris, France  
 Telephone: 33-(0)1 44 15 18 88  
 Fax: 33-(0)1 42 67 09 87  
 Electronic mail: oie@oie.int  
 WWW: <http://www.oie.int>

### **Competent Authority**

~~means the Veterinary Services, or other Authority of a Member, having the responsibility and competence for ensuring or supervising the implementation of the aquatic animal health measures or other standards in the Aquatic Code~~

means the Veterinary Authority or other Governmental Authority of an OIE Member having the responsibility and competence for ensuring or supervising the implementation of aquatic animal health and welfare measures, international health certification and other standards and recommendations in the Aquatic Code in the whole territory.

### **Early detection system**

means an efficient system for ensuring the rapid recognition of signs that are suspicious of a *listed disease*, or an *emerging disease* situation, or unexplained mortality, in *aquatic animals* in an *aquaculture establishment* or in the wild, and the rapid communication of the event to the *Competent Authority*, with the aim of activating diagnostic investigation with minimal delay.

Such a system will include the following characteristics:

- a) broad awareness, e.g. among the personnel employed at *aquaculture establishments* or involved in processing, of the characteristic signs of the *listed diseases* and *emerging diseases*,
- b) *veterinarians* or *aquatic animal health specialists* professionals trained in recognising and reporting suspicious of disease occurrence;
- c) ability of the *Competent Authority* to undertake rapid and effective *disease* investigation based on a national chain of command;

## Annex III (contd)

- d) access by the *Competent Authority* to laboratories with the facilities for diagnosing and differentiating *listed diseases* and *emerging diseases*;
- e) the legal obligation of private *veterinarians* or *aquatic animal* health professionals to report suspicions of *disease* occurrence to the *Veterinary Authority* or other *Competent Authority*.

**Emerging disease**

~~means a newly recognised serious *disease*, the cause of which may or may not yet be established, that has the potential to be spread within and between populations, for example by way of trade in *aquatic animals* and/or *aquatic animal products*.~~

means a newly recognised *infection* resulting from the evolution or change of an existing pathogenic agent, a known *infection* spreading to a new geographic area or population, or a previously unrecognised pathogenic agent or *disease* diagnosed for the first time and which has a significant impact on *aquatic animal* or public health.

**Feed additives**

~~means any ingredient intentionally added in micro amounts not normally consumed as *feed* by itself, whether or not it has nutritional value or other effect on the animal, which affects the characteristics of *feed* or of the animal products. Micro organisms, enzymes, acidity regulators, trace elements, vitamins, substances used to attract *aquatic animals* to feed and promote *feed* intake, pigments, synthetic binders, synthetic amino acids, antioxidants and other products fall within the scope of this definition, depending on the purpose of use and method of administration. This excludes veterinary drugs.~~

means any intentionally added ingredient not normally consumed as feed by itself, whether or not it has nutritional value or other effect on the *animal*, which affects the characteristics of feed of the *animal* products. Microorganisms, enzymes, pH regulators, trace elements, vitamins and other products fall within the scope of this definition depending on the purpose of use and method of administration. This excludes veterinary drugs.

**Hazard**

~~means any pathogen that could produce adverse consequences on the importation of a *commodity*.~~

means a biological, chemical or physical agent in, or a condition of, an *aquatic animal* or *aquatic animal product* with the potential to cause an adverse effect on *aquatic animal* health or public health.

**Infected zone**

means a *zone* in which a *disease* has been diagnosed. The *infected zone* must be clearly defined by the *Competent Authority(ies)* concerned and may be separated from the rest of the country by a ~~buffer~~ protection zone.

**International aquatic animal health certificate**

~~means a certificate issued by a member of the *personnel of the Competent Authority* of the *exporting country*, certifying the state of health of the *aquatic animals*, and a declaration that the *aquatic animals* originate from a source subjected to official health *surveillance* according to the procedures described in the *Aquatic Manual*.~~

means a certificate, issued in conformity with the provisions of Chapter 5.10., describing the *aquatic animal* health and/or public health requirements which are fulfilled by the exported *commodities*.

**Pathological material**

~~means tissues, organs, fluids, etc., from aquatic animals, or strains of infectious organisms (which could be identified as an isolate or biovar) to be sent to an aquatic animal disease laboratory or to a reference laboratory recognised by the OIE, the World Health Organization (WHO), the Food and Agriculture Organization of the United Nations (FAO), the European Union (EU), etc.~~

means samples obtained from live or dead aquatic animals, containing or suspected of containing infectious or parasitic agents, to be sent to a laboratory.

**Personnel of the Competent Authority**

~~means any competent personnel working within the body of, or designated by, the Competent Authority.~~

**Slaughtering**

~~means the killing and bleeding of fish.~~

**Susceptible species**

means a species of *aquatic animal* in which *infection* has been demonstrated by natural *cases* or by experimental exposures to the *disease agent* that mimics the natural pathways for *infection*. Each *disease* chapter in the *Aquatic Code* and *Aquatic Manual* contains a list of currently known *susceptible species*.

**Veterinary Services**

~~means the Veterinary Administration, all the Veterinary Authorities, and all persons authorised, registered or licensed by the veterinary statutory body.~~

means the governmental and non-governmental organisations that implement animal health and welfare measures and other standards and recommendations in the OIE Codes in the territory. The Veterinary Services are under the overall control and direction of the Veterinary Authority. Private sector organisations, veterinarians, veterinary paraprofessionals or aquatic animal professionals are normally accredited or approved by the Veterinary Authority to deliver the delegated functions.

---

-----  
- text deleted





## CHAPTER 1.3.

**DISEASES LISTED BY THE OIE**

**Preamble:** The following *diseases* are listed by the OIE according to the criteria for listing an *aquatic animal disease* (see Article 1.2.1.) or criteria for listing an *emerging aquatic animal disease* (see Article 1.2.2.).

## Article 1.3.1.

The following *diseases* of fish are listed by the OIE:

- Epizootic haematopoietic necrosis
- Infectious haematopoietic necrosis
- Spring viraemia of carp
- Viral haemorrhagic septicaemia
- Infectious salmon anaemia
- Epizootic ulcerative syndrome
- Gyrodactylosis (*Gyrodactylus salaris*)
- Red sea bream iridoviral disease
- Koi herpesvirus disease.

## Article 1.3.2.

The following *diseases* of molluscs are listed by the OIE:

- Infection with *Bonamia ostreae*
- Infection with *Bonamia exitiosa*
- Infection with *Marteilia refringens*
- Infection with *Perkinsus marinus*
- Infection with *Perkinsus olseni*
- Infection with *Xenohaliotis californiensis*
- Infection with abalone herpes-like virus.

## Article 1.3.3.

The following *diseases* of crustaceans are listed by the OIE:

- Taura syndrome
- White spot disease
- Yellow head disease
- Infectious hypodermal and haematopoietic necrosis
- Crayfish plague (*Aphanomyces astaci*)
- **Necrotising hepatopancreatitis †**
- Infectious myonecrosis
- White tail disease
- Milky haemolymph disease of spiny lobsters (*Panulirus* spp.) <sup>1</sup>.

Annex IV (contd)

Article 1.3.4.

The following *diseases* of amphibians are listed by the OIE:

- Infection with *Batrachochytrium dendrobatidis*
- Infection with ranavirus.

---

-----  
- text deleted

1. Listing of this disease is under study.

**REVISED ARTICLES X.X.3. AND X.X.9.  
AND X.X.12.**

**AN EXAMPLE (DISEASE X)  
TO BE APPLIED ACROSS ALL DISEASE CHAPTERS  
(SECTIONS 8, 9, 10 AND 11)**

Article X.X.3.

**Importation or transit of aquatic animal products for any purpose regardless of the Disease X status of the exporting country, zone or compartment**

1. *Competent Authorities* should not require any Disease X related conditions, regardless of the Disease X status of the *exporting country, zone or compartment* when authorising the importation or transit of the following *commodities* from the species referred to in Article X.X.2. intended for any purpose and complying with Article 5.3.1.:
  - (i) aquatic animal product(s). **As currently listed in the *Aquatic Code* for each disease specific chapter. This list is considered under study until specific assessments have been completed and adopted.\* ]** (under study)
2. When authorising the importation or transit of *commodities* of a species referred to in Article X.X.2., other than those referred to in point 1 of Article X.X.3., *Competent Authorities* should require the conditions prescribed in Articles X.X.7. to X.X.12. relevant to the Disease X status of the *exporting country, zone or compartment*.
3. When considering the importation or transit of a *commodity* from an *exporting country, zone or compartment* not declared free of Disease X from a species not covered in Article X.X.2. but which could reasonably be expected to pose a risk of transmission for Disease X, *Competent Authorities* should conduct a *risk analysis* in accordance with the recommendations in the *Aquatic Code*. The *exporting country* should be informed of the outcome of this assessment.

[...]

Article X.X.9.

**Importation of live aquatic animals and aquatic animal products for processing for human consumption from a country, zone or compartment not declared free from Disease X**

When importing, for processing for human consumption, live *aquatic animals* and *aquatic animal products* of the species referred to in Article X.X.2. from a country, *zone or compartment* not declared free from Disease X, the *Competent Authority* of the *importing country* should assess the *risk* and, if justified, require that:

1. the consignment is delivered directly to and held in *quarantine* or containment facilities for processing to one of the products referred to in point 1 of Article X.X.3., or products described in point 1 of Article X.X.12., or other products authorised by the *Competent Authority*; and
2. all effluent and waste material from the processing are treated in a manner that ensures inactivation of Disease agent X or is disposed in a manner that prevents contact of waste with susceptible species.

Annex V (contd)

For these *commodities* Members may wish to consider introducing internal measures to address the *risks* associated with the *commodity* being used for any purpose other than for human consumption.

[...]

Article X.X.12. (fish chapters) /Article X.X.11. (mollusc and crustacean chapters)

**Importation of live aquatic animals and aquatic animal products for retail trade for human consumption from a country, zone or compartment not declared free from Disease X**

1. *Competent Authorities* should not require any Disease X related conditions, regardless of the Disease X status of the *exporting country, zone or compartment* when authorising the importation or transit of the following *commodities* which have been prepared and packaged for retail trade and complying with Article 5.3.2.:
  - (i) *commodity* (s). As currently listed in the *Aquatic Code* for each disease specific chapter. This list is considered under study until specific assessments have been completed and adopted.\*] (under study)

For these *commodities* Members may wish to consider introducing internal measures to address the *risks* associated with the *commodity* being used for any purpose other than for human consumption.

2. When importing *live aquatic animals or aquatic animal products*, other than those referred to in point 1 above, of the species referred to in Article X.X.2. from a country, *zone* or *compartment* not declared free from Disease X, the *Competent Authority* of the *importing country* should assess the *risk* and apply appropriate *risk* mitigation measures.

\* the highlighted text is an explanatory note only.

## CHAPTER 10.1.

## EPIZOOTIC HAEMATOPOIETIC NECROSIS

[...]

Article 10.1.3.

**~~Commodities~~–Importation or transit of aquatic animal products for any purpose regardless of the EHN status of the exporting country, zone or compartment**

1. ~~When authorising the importation or transit of the following commodities, the Competent Authorities should not require any EHN related conditions, regardless of the EHN status of the exporting country, zone or compartment~~ when authorising the importation or transit of the following commodities from the species referred to in Article 10.1.2. intended for any purpose and complying with Article 5.3.1.:

- a) ~~From the species referred to in Article 10.1.2. intended for any purpose:~~
- i) ~~commodities treated in a manner that inactivates the disease agent e.g. fish skin leather<sup>1</sup> made from fish skin;~~
  - ii) pasteurised products<sup>2</sup> and some ready to eat meals; and
  - iii) fish oil<sup>3</sup>; and
  - iv) fish meal<sup>4</sup> intended for use in feed;
  - ii) ~~biological samples preserved for diagnostic applications in such a manner as to inactivate the disease agent.~~
- b) ~~The following commodities destined for human consumption from the species referred to in Article 10.1.2. which have been prepared and packaged for direct retail trade:~~
- i) ~~viscerated fish (chilled or frozen);~~
  - ii) ~~fillets or cutlets (chilled or frozen);~~
  - iii) ~~dried viscerated fish (including air dried, flame dried and sun dried).~~

~~For the commodities referred to in point 1b), OIE Members may wish to consider introducing internal measures to address the risks associated with the commodity being used for any purpose other than for human consumption.~~

---

<sup>1</sup> Refer to page 20 of Annex XXV for the assessment of this product undertaken by the *ad hoc* Group.

<sup>2</sup> Refer to page 21 of Annex XXV for the assessment of this product undertaken by the *ad hoc* Group.

<sup>3</sup> Refer to page 22 of Annex XXV for the assessment of this product undertaken by the *ad hoc* Group.

<sup>4</sup> Refer to page 22 of Annex XXV for the assessment of this product undertaken by the *ad hoc* Group.

Annex VI (contd)

2. When authorising the importation or transit of *commodities* of a species referred to in Article 10.1.2., other than those referred to in point 1 of Article 10.1.3., ~~the~~ *Competent Authorities* should require the conditions prescribed in Articles 10.1.7. to 10.1.12. relevant to the EHN status of the *exporting country, zone or compartment*.
3. When considering the importation ~~or transit of a commodity~~ or transit of a commodity from an *exporting country, zone or compartment* not declared free of EHN ~~of a live commodity~~ from a species not covered in Article 10.1.2. but which could reasonably be expected to pose a risk of transmission ~~be a potential mechanical vector~~ for EHN, ~~the~~ *Competent Authorities* should conduct a *risk analysis* in accordance with the recommendations in the *Aquatic Code*. The *exporting country* should be informed of the outcome of this assessment.

[...]

Article 10.1.9.

**Importation of live aquatic animals and aquatic animal products for processing for human consumption from a country, zone or compartment not declared free from epizootic haematopoietic necrosis**

When importing, for processing for human consumption, live *aquatic animals* and aquatic animal products of the species referred to in Article 10.1.2. from a country, *zone or compartment* not declared free from EHN, the *Competent Authority* of the *importing country* should assess the *risk* and, if justified, require that:

1. the consignment ~~be is~~ delivered directly to and held in *quarantine* or containment facilities for ~~slaughter and~~ processing to one of the products referred to in point 1 of Article 10.1.3., or products described in point 1 of Article 10.1.12., or other products authorised by the *Competent Authority*; and
2. all effluent and waste material from the processing are treated in a manner that ensures inactivation of EHN or is disposed in a manner that prevents contact of waste with susceptible species.

For these commodities ~~OIE~~ Members may wish to consider introducing internal measures to address the risks associated with the commodity ~~prevent such commodities~~ being used for any purpose other than for human consumption.

~~This Article does not apply to commodities referred to in point 1 of Article 10.1.3.~~

[...]

Article 10.1.12.

**Importation of live aquatic animals and aquatic animal products for retail trade for human consumption from a country, zone or compartment not declared free from epizootic haematopoietic necrosis**

1. Competent Authorities should not require any EHV related conditions, regardless of the EHV status of the exporting country, zone or compartment when authorising the importation or transit of the following commodities which have been prepared and packaged for retail trade and complying with Article 5.3.2.:

- ~~i) visceral fish (chilled or frozen)<sup>5</sup>~~
- ~~ii) fillets or steaks ~~cutlets~~ (chilled or frozen)<sup>6</sup>; and~~
- ~~iii) artificially dried visceral fish<sup>7</sup> (including air dried, flame dried and sun dried).~~

For these commodities Members may wish to consider introducing internal measures to address the risks associated with the commodity being used for any purpose other than for human consumption.

2. When importing live aquatic animals and aquatic animal products other than those referred to in point 1 above, of the species referred to in Article 10.1.2. from a country, zone or compartment not declared free from EHV, the *Competent Authority* of the *importing country* should assess the *risk* and apply appropriate *risk* mitigation measures.

~~In the case of dead fish, whether *visceral* or *unvisceral*, such *risk* mitigation measures may include:~~

- ~~1. the direct delivery into and holding of the consignment in facilities for processing to one of the products referred to in point 1 of Article 10.1.3. or other products authorised by the *Competent Authority*;~~
- ~~2. the treatment of all effluent and waste material in a manner that ensures inactivation of EHNIV.~~

~~This Article does not apply to *commodities* referred to in point 1 of Article 10.1.3.~~

---

-----  
- text deleted

---

<sup>5</sup> Refer to page 23 of Annex XXV for the assessment of this product undertaken by the *ad hoc* Group.

<sup>6</sup> Refer to page 24 of Annex XXV for the assessment of this product undertaken by the *ad hoc* Group.

<sup>7</sup> Refer to page 24 and 25 of Annex XXV for the assessment of this product undertaken by the *ad hoc* Group.





## CHAPTER 9.4.

## TAURA SYNDROME

[...]

Article 9.4.3.

**Commodities Importation or transit of aquatic animal products for any purpose regardless of the Taura Syndrome status of the exporting country, zone or compartment**

1. ~~When authorising the importation or transit of the following commodities, the Competent Authorities should not require any TS related conditions, regardless of the TS status of the exporting country, zone or compartment when authorising the importation or transit of the following commodities from the species referred to in Article 9.2.2. intended for any purpose and complying with Article 5.3.1.:~~
- a) ~~For the species referred to in Article 9.4.2. intended for any purpose:~~
- ~~i) commodities treated in a manner that inactivates the disease agent e.g. boiled-cooked products<sup>8</sup>~~
  - ~~ii) canned products; <sup>9</sup> ~~or pasteurised products~~ <sup>10</sup> ~~and some ready to eat meals; and~~~~
  - ~~iii) crustacean oil<sup>11</sup>; ~~and~~~~
  - ~~iv) crustacean meal<sup>12</sup> ~~intended for use in feed,~~~~
  - ~~v) chemically extracted chitin<sup>13</sup>.~~
  - ~~iii) crustacean products made non infectious through processing as dry feed (e.g. pelleted or extruded feed); <sup>14</sup>~~
  - ~~iv) biological samples preserved for diagnostic applications in such a manner as to inactivate the disease agent.~~
- b) ~~{The following products destined for human consumption from species referred to in Article 9.4.2. which have been prepared and packaged for direct retail trade:~~

<sup>8</sup> Refer to page 33 of Annex XXV for the assessment of this product undertaken by the *ad hoc* Group.

<sup>9</sup> Refer to page 32 of Annex XXV for the assessment of this product undertaken by the *ad hoc* Group.

<sup>10</sup> Refer to page 31 of Annex XXV for the assessment of this product undertaken by the *ad hoc* Group.

<sup>11</sup> Refer to page 29 of Annex XXV for the assessment of this product undertaken by the *ad hoc* Group.

<sup>12</sup> Refer to page 28 of Annex XXV for the assessment of this product undertaken by the *ad hoc* Group.

<sup>13</sup> Refer to page 30 of Annex XXV for the assessment of this product undertaken by the *ad hoc* Group.

<sup>14</sup> Refer to page 28 of Annex XXV for the assessment of this product undertaken by the *ad hoc* Group.

Annex VI (contd)

For the *commodities* listed in point 1b), OIE Members may wish to consider introducing internal measures to address the *risks* associated with the *commodity* being used for any purpose other than for human consumption. (under study)

2. When authorising the importation or transit of the *commodities* of a species referred to in Article 9.4.2., other than those listed in point 1 of Article 9.4.3., ~~the~~ *Competent Authorities* should require the conditions prescribed in Articles 9.4.7. to 9.4.11. relevant to the TS status of the *exporting country, zone or compartment*.
3. When considering the importation/ or transit of a commodity from an *exporting country, zone or compartment* not declared free of TS ~~of a commodity of from~~ a species not covered in Article 9.4.2. but which could reasonably be expected to pose a risk of transmission ~~be a potential mechanical vector~~ for TSV, ~~the~~ *Competent Authorities* should conduct a *risk analysis* in accordance with the recommendations in the *Aquatic Code*. The *exporting country* should be informed of the outcome of this assessment.

[...]

Article 9.4.9.

**Importation of live aquatic animals and aquatic animal products for processing for human consumption from a country, zone or compartment not declared free from Taura syndrome**

When importing, for processing for human consumption, live *aquatic animals* and *aquatic animal products* of the species referred to in Article 9.4.2. from a country, *zone* or *compartment* not declared free from TS, the *Competent Authority* of the *importing country* should assess the *risk* and, if justified, require that:

1. the consignment ~~be~~ is delivered directly to and held in quarantine or containment facilities ~~isolation until for processing and/or consumption; to one of the products referred to in point 1 of Article 9.4.3., or products described in point 1 of Article 9.4.11., or other products authorised by the~~ Competent Authority; and
2. all effluent, ~~dead aquatic animals~~ and waste materials from the processing ~~be~~ are treated in a manner that ensures inactivation of TSV or is disposed in a manner that prevents contact of waste with susceptible species

For these commodities ~~OIE~~ Members may wish to consider introducing internal measures to address the risks associated with the prevent such commodities being used for any purpose other than for human consumption.

~~This Article does not apply to commodities listed in point 1 of Article 9.4.3.~~

[...]

Article 9.4.11.

**Importation of live aquatic animals and aquatic animal products for retail trade for human consumption from a country, zone or compartment not declared free from Taura syndrome**

1. Competent Authorities should not require any TS related conditions, regardless of the TS status of the exporting country, zone or compartment when authorising the importation or transit of the following commodities which have been prepared and packaged for retail trade and complying with Article 5.3.2.:
  - (i) frozen, peeled shrimp (shell off, head off) (under study)<sup>15</sup>.

<sup>15</sup> Refer to page 35 of Annex XXV for the assessment of this product undertaken by the *ad hoc* Group.

For these commodities Members may wish to consider introducing internal measures to address the risks associated with the commodity being used for any purpose other than for human consumption.

2. When importing live aquatic animals or aquatic animal products, other than those referred to in point 1 above, of the species referred to in Article 9.4.2. from a country, zone or compartment not declared free from TS, the Competent Authority of the importing country should assess the risk and apply appropriate risk mitigation measures.

~~This Article does not apply to commodities listed in point 1 of Article 9.4.3.~~

---

-----  
- text deleted



## CHAPTER 11.2.

INFECTION WITH *BONAMIA OSTREAE*

[...]

Article 11.2.3.

**Commodities Importation or transit of aquatic animal products for any purpose regardless of the *B. ostreae* status of the exporting country, zone or compartment**

1. ~~When authorising the importation or transit of the following commodities, the Competent Authorities should not require any *B. ostreae* related conditions, regardless of the *B. ostreae* status of the exporting country, zone or compartment when authorising the importation or transit of the following commodities from the species referred to in Article 11.2.2. intended for any purpose and complying with Article 5.3.1.:~~
  - a) ~~From the species referred to in Article 11.2.2. intended for any purpose:~~
    - i) ~~commodities treated in a manner that inactivates the disease agent e.g. canned<sup>16</sup> or~~
    - ii) pasteurised products<sup>17</sup>
    - ii) ~~biological samples preserved for diagnostic applications in such a manner as to inactivate the disease agent.~~
  - b) ~~The following commodities destined for human consumption from the species referred to in Article 11.2.2. which have been prepared and packaged for direct retail trade:~~
    - i) ~~off the shell (chilled or frozen);<sup>18</sup>~~
    - ii) ~~half shell (chilled).<sup>19</sup>~~
  - e) ~~All commodities from *Crasso streagigas*, *C. virginica*, *Rudit apesdecussa tus*, *R. philippin arum*, *Mytilusgallio provincialis* and *M.edulis*, including the live aquatic animal.~~

~~For the commodities referred to in point 1b), OIE Members may wish to consider introducing internal measures to address the risks associated with the commodity being used for any purpose other than for human consumption.~~

2. When authorising the importation or transit of commodities of a species referred to in Article 11.1.2., other than those referred to in point 1 of Article 11.2.3., ~~the~~ Competent Authorities should require the conditions prescribed in Articles 11.2.7. to 11.2.11. relevant to the *B. ostreae* status of the exporting country, zone or compartment.

<sup>16</sup> Refer to page 39 of Annex XXV for the assessment of this product undertaken by the *ad hoc* Group.

<sup>17</sup> Refer to page 39 of Annex XXV for the assessment of this product undertaken by the *ad hoc* Group.

<sup>18</sup> Refer to page 40 of Annex XXV for the assessment of this product undertaken by the *ad hoc* Group.

<sup>19</sup> Refer to page 40 of Annex XXV for the assessment of this product undertaken by the *ad hoc* Group.

## Annex VI (contd)

3. When considering the importation/ or transit of a commodity from an *exporting country, zone or compartment* not declared free of infection with *B. ostreae* ~~of a commodity from bivalve~~ a species not covered in Article 11.2.2. ~~or in point 1e) of Article 11.2.3.~~ but which could reasonably be expected to pose a risk of transmission ~~be a potential mechanical vector~~ for *B. ostreae*, ~~the~~ *Competent Authorities* should conduct a *risk analysis* in accordance with the recommendations in the *Aquatic Code*. The *exporting country* should be informed of the outcome of this assessment.

[...]

Article 11.2.9.

**Importation of live aquatic animals and aquatic animal products for processing for human consumption from a country, zone or compartment not declared free from *B. ostreae***

When importing, for processing for human consumption, live *aquatic animals* and aquatic animal products of the species referred to in Article 11.2.2. from a country, *zone or compartment* not declared free from *B. ostreae*, the *Competent Authority* of the *importing country* should assess the *risk* and, if justified, require that:

1. the consignment ~~be is~~ delivered directly to and held in quarantine or containment facilities ~~until for~~ processing and/or consumption to one of the products referred to in point 1 of Article 11.2.3., or products described in point 1 of Article 11.2.11., or other products authorised by the *Competent Authority* and
2. all effluent and waste material from the processing are treated in a manner that ensures inactivation of *B. ostreae* or is disposed in a manner that prevents contact of waste with susceptible species.

For these commodities Members may wish to consider introducing internal measures to address the risks associated with the commodity being used for any purpose other than for human consumption.

~~This Article does not apply to commodities referred to in point 1 of Article 11.1.3.~~

[...]

Article 11.2.11.

**Importation of live aquatic animals and aquatic animal products for retail trade for human consumption from a country, zone or compartment not declared free from *B. ostreae***

1. *Competent Authorities* should not require any *B. ostreae* related conditions, regardless of the *B. ostreae* status of the *exporting country, zone or compartment* when authorising the importation or transit of the following commodities which have been prepared and packaged for retail trade and complying with Article 5.3.2.:
  - i) off the shell oyster meat (chilled or frozen);
  - ii) half-shell (chilled or frozen).

For these commodities Members may wish to consider introducing internal measures to address the risks associated with the commodity being used for any purpose other than for human consumption.

2. When importing live aquatic animals or aquatic animal products other than those referred to in point 1 above, of the species referred to in Article 11.2.2. from a country, *zone or compartment* not declared free from *B. ostreae*, the *Competent Authority* of the *importing country* should assess the *risk* and apply appropriate *risk* mitigation measures.

~~This Article does not apply to *commodities* referred to in point 1 of Article 10.1.3.~~

-----

– text deleted





Highlighted text shows changes required to align Articles with the proposed changes to Articles X.X.3, X.X.9, X.X.12.

## CHAPTER 5.3.

# CRITERIA TO ASSESS THE SAFETY OF AQUATIC ANIMAL COMMODITIES

In the context of this chapter the word safety is applied only to animal health considerations for OIE listed diseases.

Article 5.3.1.

### **Criteria to assess the safety of aquatic animal products ~~commodities~~ irrespective regardless of ~~country~~ disease status**

In all *disease* chapters, point 1a) of Article X.X.3. lists ~~commodities~~ aquatic animal products that can be traded ~~irrespective~~ regardless of ~~country~~ disease status. The criteria for inclusion of ~~commodities~~ aquatic animal products in point 1a) of Article X.X.3. are based on the absence of the *disease agent* in the traded ~~commodity~~ aquatic animal product or inactivation of the *disease agent* by treatment or processing.

The assessment of the safety of the ~~commodity~~ aquatic animal product using the criteria relating to treatment or processing can only be undertaken where treatments or processing are well defined. It may not be necessary to provide details of the entire treatment or process undertaken. However, the steps considered critical in the inactivation of the *disease agent* of concern should be detailed.

It is assumed that treatment or processing (i) uses standardised protocols, which include the steps considered critical in the inactivation of the *disease agent* of concern; (ii) is conducted according to Good Manufacturing Practices; and (iii) that any other steps in the treatment, processing and subsequent handling of the ~~commodity~~ aquatic animal product do not jeopardise the safety of the traded ~~commodity~~ aquatic animal product.

For an ~~an~~ ~~commodity~~ aquatic animal product to be considered safe for *international trade* under the provisions of ~~point 1a) of~~ Article X.X.3., it should comply with the following criteria:

1. Absence of *disease agent* in the traded ~~commodity~~ aquatic animal product:
  - a) There is strong evidence that the *disease agent* is not present in the tissues from which the ~~commodity~~ aquatic animal product is derived.

AND

- b) The water (including ice) used to process or transport the ~~commodity~~ aquatic animal product is not contaminated with the *disease agent* and the processing prevents cross contamination of the ~~commodity~~ aquatic animal product to be traded.

OR

Annex VII (contd)

2. Even if the *disease agent* is present in, or contaminates the tissues from which the ~~commodity~~ aquatic animal product is derived, the treatment or processing to produce the ~~commodity~~ aquatic animal product to be traded inactivates the *disease agent*:
- a) physical (e.g. temperature, drying, smoking);
- AND/OR
- b) chemical (e.g. iodine, pH, salt, smoke);
- AND/OR
- c) biological (e.g. fermentation).

Article 5.3.2.

**Criteria to assess the safety of live aquatic animals or of aquatic animal products destined for retail trade for human consumption from a country, zone or compartment not declared free of a irrespective of country disease status**

In all *disease* chapters, point 1 ~~b~~ of Article X.X.123. (fish disease chapters) and: Article X.X.X.11. (mollusc and crustacean disease chapters) lists live aquatic animals or aquatic animal products for retail trade destined for human consumption. The criteria for inclusion of live aquatic animals or aquatic animal products in point 1 ~~b~~ of Article X.X.123. include consideration of the form and presentation of the product, the expected volume of waste tissues generated by the consumer and the likely quantity of viable *disease agent* in the waste.

For the purpose of this criterion retail means the selling or provision of live aquatic animals or aquatic animal products directly to the consumer with the intended purpose of human consumption. The retail pathway may also include wholesale distribution of the products provided they are not further processed by the wholesale distributor or the retailer, i.e. are not subjected to actions such as gutting, cleaning, filleting, freezing, thawing, cooking, unpacking, packing or repackaging.

It is assumed that:

- (i) the live aquatic animals or aquatic animal products ~~is~~ are used for human consumption only;
- (ii) waste may not always be handled in an appropriate manner that mitigates the introduction of the disease agent. The level of risk is related to the waste disposal practices in each Member's country or territory;
- (iii) treatment or processing prior to importation ~~(i) uses standardised protocols, which include the steps considered critical in the inactivation of the disease agent of concern; and (ii) is conducted according to Good Manufacturing Practices; and (iii)~~
- (iv) ~~that~~ any other steps in the treatment, processing and subsequent handling of the live aquatic animals or aquatic animal products prior to importation do not jeopardise the safety of the traded live aquatic animals or aquatic animal products

For live aquatic animals or aquatic animal products to be considered ~~safe~~ for *international trade* under the provisions of point 1 ~~b~~ of Article X.X.123. (fish disease chapters); Article X.X.X.11. (mollusc and crustacean disease chapters), it should comply with the following criteria:

Annex VII (contd)

1. the live aquatic animals or aquatic animal product is prepared and packaged for retail trade for human consumption; AND

EITHER

2. it includes only a small amount of waste tissues;

OR

3. ~~viable disease agent is unlikely to be present in the waste tissues, because:~~

- a) ~~the disease agent is not normally found in the waste tissues;~~

~~OR~~

- b) ~~the disease agent may be present in the waste tissues but the processing prior to importation involves processes known to inactivate and/or reduce the load of disease agent:~~

- i) ~~physical (e.g. temperature, drying, smoking);~~

~~OR~~

- ii) ~~chemical (e.g. pH, salt, smoke);~~

~~OR~~

- iii) ~~biological (e.g. fermentation).~~

---

-----  
- text deleted



CHAPTER 5.9MEASURES CONCERNING INTERNATIONAL  
TRANSPORT OF AQUATIC ANIMAL DISEASE AGENTS  
AND PATHOLOGICAL MATERIALArticle 5.9.1**Introduction**

There is the *risk* that *disease* may occur as a result of the accidental release of *aquatic animal* pathogens during international transport of packaged materials. Such pathogens may already occur in the country or they may have been imported deliberately or inadvertently. It is herefore necessary to have in place measures to prevent their accidental release. These measures may be applied at national borders by prohibiting or controlling the importation of specified *aquatic animal* pathogens or *pathological material*, which may contain them.

Competent Authorities should not require sanitary measures for biological samples preserved for diagnostic applications that are treated in such a manner as to inactivate the disease agent and will not cause aquatic animal disease.

## Article 5.9.2.

[...]

-----  
- text deleted



## CHAPTER 2.2.

**IMPORT RISK ANALYSIS**

[...]

Article 2.2.3.

**Principles of risk assessment**

1. *Risk assessment* should be flexible to deal with the complexity of real life situations. No single method is applicable in all cases. *Risk assessment* must be able to accommodate the variety of animal *commodities*, the multiple *hazards* that may be identified with an importation and the specificity of each *disease*, detection and *surveillance* systems, exposure scenarios and types and amounts of data and information.
2. Both *qualitative risk assessment* and *quantitative risk assessment* methods are valid. ~~Although quantitative assessment is recognised as being able to provide deeper insights into a particular problem, qualitative methods may be more relevant when available data are limited.~~

[...]

-----  
- text deleted





## CHAPTER 3.1.

## QUALITY OF COMPETENT AUTHORITIES

## Article 3.1.1.

The quality of *Competent Authorities* depends on multiple factors that include fundamental principles of an ethical, organisational, legislative and technical nature. *Competent Authorities* should conform to these fundamental principles, regardless of the political, economic or social situation of their country.

Compliance with these fundamental principles by the *Competent Authority* of an OIE Member Country or Territory (Member) is important to the establishment and maintenance of confidence in its *international aquatic animal health certificates* by *Competent Authorities* of other Members.

These fundamental principles are presented in Article 3.1.2. Other factors affecting the quality of *Competent Authorities* are described in the *Aquatic Code* (*notification, principles of certification, etc.*).

The quality of *Competent Authorities*, including aquatic animal health legislation, can be measured through an evaluation, the general principles of which are described in Article 3.1.3. and in Article 3.1.4.

A procedure for evaluating *Competent Authorities* by OIE experts, on a voluntary basis, is described in Article 3.1.5.

## Article 3.1.2.

**Fundamental principles of quality**

*Competent Authorities* should comply with the following principles to ensure the quality of their activities:

1. Professional judgement

The personnel of *Competent Authorities* should have the relevant qualifications, scientific expertise and experience to give them the competence to make sound professional judgements.

2. Independence

Care should be taken to ensure that the *Competent Authority* personnel are free from any commercial, financial, hierarchical, political or other pressures which might affect their judgement or decisions.

3. Impartiality

*Competent Authorities* should be impartial. In particular, all the parties affected by their activities have a right to expect their services to be delivered under reasonable and non-discriminatory conditions.

4. Integrity

*Competent Authorities* should guarantee that the work of each of their personnel is of a consistently high level of integrity. Any fraud, corruption or falsification should be identified, documented and corrected.

Annex X (contd)5. Objectivity

*Competent Authorities* should at all times act in an objective, transparent and non-discriminatory manner.

6. Aquatic animal health legislation

Aquatic animal health legislation is a fundamental element of quality as it supports good governance and provides the legal framework for all key activities of the *Competent Authority*.

Legislation should be suitably flexible to allow for judgements of equivalence and efficient responses to changing situations. In particular, it should define and document the responsibilities and structure of the organisations in charge of the animal identification system, control of *aquatic animal* movements, *aquatic animal* disease control and reporting systems, epidemiological surveillance and communication of epidemiological information.

A similar demonstration should be made by *Competent Authorities* when they are in charge of veterinary public health activities.

67. General organisation

*Competent Authorities* must be able to demonstrate by means of an appropriate legislation regulatory framework, sufficient financial resources and effective organisation that they are in a position to have control of the establishment and application of *aquatic animal* health measures, and of international *aquatic animal* health certification activities. ~~The regulatory framework should be suitably flexible to allow for judgements of equivalence and efficient responses to changing situations. In particular, such frameworks should define and document the responsibilities and structure of the organisations in charge of the control of *aquatic animal* movements, *aquatic animal* disease control and reporting systems, epidemiological surveillance and communication of epidemiological information.~~

~~A similar demonstration should be made by *Competent Authorities* when they are in charge of veterinary public health activities.~~

*Competent Authorities* should have at their disposal effective systems for *aquatic animal* disease surveillance, diagnosis and notification of disease problems that may occur in the national territory, in accordance with the provisions of the *Aquatic Code*. They should at all times endeavour to improve their performance in terms of *aquatic animal* health information systems and *aquatic animal* disease control.

*Competent Authorities* should define and document the responsibilities and structure of the organisation (in particular the chain of command) in charge of issuing *international aquatic animal health certificates*.

Each position within the *Competent Authority* that has an impact on their quality should be described.

These job descriptions should include the requirements for education, training, technical knowledge and experience.

78. Quality policy

*Competent Authorities* should define and document their policy and objectives for, and commitment to, quality, and should ensure that this policy is understood, implemented and maintained at all levels in the organisation. Where conditions allow, they may implement a quality system corresponding to their areas of activity and appropriate for the type, range and volume of work that they have to perform. The recommendations provided in this chapter describe a suitable reference system, which should be used if a Member chooses to adopt a quality system.

**89. Procedures and standards**

*Competent Authorities* should develop and document appropriate procedures and standards for all providers of relevant activities and associated facilities. These procedures and standards may for example relate to:

- a) programming and management of activities, including international *aquatic animal* health certification activities;
- b) prevention, control and *notification of disease outbreaks*;
- c) *risk analysis*, epidemiological *surveillance* and zoning;
- d) inspection and sampling techniques;
- e) diagnostic tests for *aquatic animal diseases*;
- f) preparation, production, registration and control of *biological products* for use in the *diagnosis* or prevention of *diseases*;
- g) border controls and import regulations;
- h) *disinfection*;
- i) treatments intended to inactivate pathogens in *aquatic animal* products.

Where there are standards in the *Aquatic Code* or in the *Aquatic Manual*, *Competent Authorities* should comply with these standards when applying *aquatic animal* health measures and when issuing *international aquatic animal health certificates*.

**90. Information, complaints and appeals**

*Competent Authorities* should undertake to reply to requests from *Competent Authorities* of other Members or any other authority, in particular ensuring that any requests for information, complaints or appeals that are presented are dealt with in a timely manner.

A record should be maintained of all complaints and appeals and of the relevant action taken by *Competent Authorities*.

**101. Documentation**

*Competent Authorities* should have at their disposal a reliable and up-to-date documentation system suited to their activities.

**112. Self-evaluation**

*Competent Authorities* should undertake periodical self-evaluation especially by documenting achievements against goals, and demonstrating the effectiveness of their organisational components and resource adequacy.

A procedure for evaluating *Competent Authorities* by OIE experts, on a voluntary basis, is described in Article 3.1.5.

Annex X (contd)1213. Communication

*Competent Authorities* should have effective internal and external systems of communication covering administrative and technical staff and parties affected by their activities.

1314. Human and financial resources

Responsible authorities should ensure that adequate resources are made available to implement effectively the above activities.

## Article 3.1.3.

For the purposes of the *Aquatic Code*, every Member should recognise the right of another Member to undertake, or request it to undertake, an evaluation of its *Competent Authority* where the initiating Member is an actual or a prospective importer of *aquatic animal commodities* and/or where the evaluation is to be a component of a *risk analysis* process that is to be used to determine or review *sanitary measures* which apply to such trade.

A Member has the right to expect that the evaluation of its *Competent Authority* will be conducted in an objective and transparent manner. A Member undertaking an evaluation should be able to justify any measure taken as a consequence of its evaluation.

## Article 3.1.4.

A Member which intends to conduct an evaluation of another Member's *Competent Authority* should provide notice in writing, and allow sufficient time for the other Member to comply with the request. This notice should define the purpose of the evaluation and details of the information required.

On receipt of a formal request for information to enable an evaluation of its *Competent Authority* by another Member, and following bilateral agreement of the evaluation process and criteria, a Member should expeditiously provide the Member requesting the evaluation with meaningful and accurate information of the type requested.

The evaluation process should take into account the fundamental principles and other factors of quality laid down in Article 3.1.1. and in Article 3.1.2. It should also take into consideration the specific circumstances regarding quality, as described in Article 3.1.1., prevailing in the countries concerned.

The outcome of an evaluation conducted by a Member should be provided in writing as soon as possible, and in any case within 4 months of receipt of the relevant information, to the Member which has undergone the evaluation. The evaluation report should detail any findings that affect trade prospects. The Member which conducts the evaluation should clarify in detail any points of the evaluation on request.

In the event of a dispute between two Members over the conduct or the conclusions of the evaluation of *Competent Authorities*, the matter should be dealt with having regard to the procedures set out in Article 3.1.3.

## Article 3.1.5.

**Evaluation facilitated by OIE experts under the auspices of the OIE**

The OIE has established procedures for the evaluation of *Competent Authorities* of Members. Members can make a request to the OIE for an evaluation of their *Competent Authority*.

The World Assembly of OIE Delegates may endorse a list of approved experts to facilitate the evaluation process.

Under these procedures, the Director General of the OIE recommends an expert(s) from that list.

The expert(s) facilitate(s) the evaluation of the *Competent Authority* of the Member using the OIE *Tool for the Evaluation of Performance of Veterinary Services (OIE PVS Tool)*, applied as appropriate to the context of the evaluation.

The expert(s) produce(s) a report in consultation with the *Competent Authority* of the Member.

The report is submitted to the Director General of the OIE and, with the consent of the Member, published by the OIE.

---

-----  
- text deleted



## CHAPTER 4.X.

## APPLICATION OF COMPARTMENTALISATION

## Article 4.X.1.

**Introduction and objectives**

The recommendations in this Chapter provide a structured framework for the application and recognition of *compartments* within countries or *zones*, based on the provisions of Chapter 4.1. with the objective to facilitate trade in *aquatic animals* and products of *aquatic animal* origin and as a tool for *disease* management.

Establishing and maintaining a disease free-status throughout the country should be the final goal for OIE Members. However, establishing and maintaining a *disease-free* status for an entire country may be difficult, especially in the case of *diseases* that can easily cross international boundaries. For many *diseases*, OIE Members have traditionally applied the concept of zoning to establish and maintain an animal *subpopulation* with a different animal health status within national boundaries.

The essential difference between zoning and compartmentalisation is that the recognition of *zones* is based on geographical boundaries whereas the recognition of *compartments* is based of management practices and biosecurity. However, spatial considerations and good management practices play a role in the application of both concepts.

The fundamental requirement for compartmentalisation is the implementation and documentation of management and biosecurity measures to create a functional separation of *subpopulations*.

For example, an *aquaculture establishment* in an infected country or *zone* might have biosecurity measures and management practices that result in negligible *risk* from *diseases* or agents. The concept of a *compartment* extends the application of a 'risk boundary' beyond that of a geographical interface and considers all epidemiological factors that can help to create an effective *disease-specific* separation between *subpopulations*.

In *disease-free* countries or *zones*, *compartments* preferably should be defined prior to the occurrence of a *disease outbreak*. In the event of an *outbreak* or in infected countries or *zones*, compartmentalisation may be used to facilitate trade.

For the purpose of *international trade*, *compartments* must be under the responsibility of the *Veterinary Authority* or other *Competent Authority* in the country. For the purposes of this Chapter, compliance by the Members with Chapters 1.1. and 3.1. is an essential prerequisite.

## Article 4.X.2.

**Principles for defining a compartment**

A *compartment* may be established with respect of a specific *disease* or *diseases*. A *compartment* must be clearly defined, indicating the location of all its components including establishments, as well as related functional units (such as brood stock facilities, hatcheries, nurseries, grow-out facilities, slaughterhouses, processing plants etc.), their interrelationships and their contribution to an epidemiological separation between the *aquatic animals* in a *compartment* and *subpopulations* with a different health status. The definition of *compartment* may revolve around *disease specific* epidemiological factors, production systems, biosecurity practices infrastructural factors and *surveillance*.

### **Separation of a compartment from potential sources of infection**

The management of a *compartment* must provide to the *Competent Authority* documented evidence on the following:

#### **1. Physical or spatial factors that affect the status of biosecurity in a compartment**

While a *compartment* is primarily based on management and biosecurity measures, a review of geographical factors is needed to ensure that the functional boundary provides adequate separation of a *compartment* from adjacent animal populations with a different health status. The following factors should be taken into consideration in conjunction with biosecurity measures and, in some instances, may alter the degree of confidence achieved by general biosecurity and *surveillance* measures:

- a) disease status in adjacent areas and in areas epidemiologically linked to the *compartment*;
- b) location, disease status and biosecurity of the nearest *epidemiological units* or other epidemiologically relevant premises. Consideration should be given to the distance and physical separation from:
  - i) *aquatic animal* populations with a different health status in close proximity to the *compartment*, including wildlife and their migratory routes;
  - ii) slaughterhouses or processing plants;
  - iii) exhibitions, 'put and take' fisheries, fish markets, restaurants with live fish and other points of *aquatic animal* concentration.

#### **2. Infrastructural factors**

Structural aspects of the *establishments* within a *compartment* contribute to the effectiveness of its biosecurity. Consideration should be given to:

- a) water supply;
- b) effective means of physical separation;
- c) facilities for people entry including access control;
- d) vehicle and vessel access including washing and disinfection procedures;
- e) unloading and loading facilities;
- f) isolation facilities for introduced *aquatic animals*;
- g) facilities for the introduction of material and equipment;
- h) infrastructure to store feed and veterinary products;
- i) disposal of carcasses;
- j) measures to prevent exposure to living mechanical or biological vectors;
- k) feed supply/source.



### 3. Biosecurity plan

The integrity of the *compartment* relies on effective biosecurity. The management of the *compartment* should develop, implement and monitor a comprehensive *biosecurity plan*.

The *biosecurity plan* should describe in detail:

- a) potential pathways for introduction and spread into the *compartment* of the agents for which the *compartment* was defined, including *aquatic animal* movements, wild aquatic animals, potential vectors, *vehicles*, people, biological products, equipment, fomites, feed, waterways, drainage or other means. Consideration should also be given to the survivability of the agent in the environment;
- b) the critical control points for each pathway;
- c) measures to mitigate exposure for each critical control point;
- d) standard operating procedures including:
  - i) implementation, maintenance, monitoring of the measures,
  - ii) application of corrective actions,
  - iii) verification of the process,
  - iv) record keeping;
- e) contingency plan in the event of a change in the level of exposure;
- f) reporting procedures to the *Veterinary Authority* or other *Competent Authority*;
- g) the programme for educating and training workers to ensure that all persons involved are knowledgeable and informed on biosecurity principles and practices;
- h) the *surveillance* programme in place.

In any case, sufficient evidence should be submitted to assess the efficacy of the *biosecurity plan* in accordance with the level of *risk* for each identified pathway. This evidence should be structured in line with the principles of Hazard Analysis and Critical Control Point (HACCP). The biosecurity risk of all operations of the *compartment* should be regularly re-assessed and documented at least on a yearly basis. Based on the outcome of the assessment, concrete and documented mitigation steps should be taken to reduce the likelihood of introduction of the disease agent into the *compartment*.

### 4. Traceability system

A prerequisite for assessing the integrity of a *compartment* is the existence of a valid *traceability system*. Although individual identification of *aquatic animals* may not be feasible, the *Veterinary Authority* or other *Competent Authority* should provide sufficient assurance of *traceability* in such a way that their history and movements can be documented and audited.

All *aquatic animal* movements into and out of the *compartment* should be recorded at the *compartment* level, and when needed, based on a *risk assessment*, certified by the *Veterinary Authority* or other *Competent Authority*. Movements within the *compartment* need not be certified but should be recorded at the *compartment* level.

Annex XI (contd)

## Article 4.X.4.

**Documentation**

Documentation must provide clear evidence that the biosecurity, *surveillance*, *traceability* and management practices defined for a *compartment* are effectively and consistently applied. In addition to animal movement information, the necessary documentation should include production unit records (e.g. cage, pond), feed sources, laboratory tests, death records, the visitor logbook, morbidity history, medication and vaccination records, *biosecurity plans*, training documentation and any other criteria necessary for the evaluation of *disease* exclusion.

The historical status of a *compartment* for the *disease(s)* for which it was defined should be documented and demonstrate compliance with the requirements for freedom in the relevant *Aquatic Code* Chapter.

In addition, a *compartment* seeking recognition should submit to the *Veterinary Authority* or other *Competent Authority* a baseline *aquatic animal* health report indicating the presence or absence of OIE *listed diseases*. This report should be regularly updated to reflect the current *aquatic animal health status* of the *compartment*.

Vaccination records including the type of vaccine and frequency of administration must be available to enable interpretation of *surveillance* data.

The time period for which all records should be kept may vary according to the species and *disease(s)* for which the *compartment* was defined.

All relevant information must be recorded in a transparent manner and be easily accessible so as to be auditable by the *Veterinary Authority* or other *Competent Authority*.

## Article 4.X.5.

**Surveillance for the disease agent or disease**

The *surveillance* system should comply with Chapter 1.4. on Surveillance and the specific recommendations for *surveillance* for the *disease(s)* for which the *compartment* was defined, if available.

If there is an increased *risk* of exposure to the agent for which the *compartment* has been defined, the detection level of the internal and external *surveillance* should be reviewed and, where necessary, raised. At the same time, biosecurity measures in place should be reassessed and increased if necessary.

1. Internal surveillance

*Surveillance* should involve the collection and analysis of *disease/infection* data so that the *Veterinary Authority* can certify that the animal *subpopulation* contained in all the *establishments* comply with the defined status of that *compartment*. A *surveillance* system that is able to ensure early detection in the event that the agent enters a *subpopulation* is essential. Depending on the *disease(s)* for which the *compartment* was defined, different *surveillance* strategies may be applied to achieve the desired confidence in *disease* freedom.

2. External surveillance

The biosecurity measures applied in a *compartment* must be appropriate to the level of exposure of the *compartment*. External *surveillance* will help identify a significant change in the level of exposure for the identified pathways for *disease* introduction into the *compartment*.

An appropriate combination of active and passive *surveillance* is necessary to achieve the goals described above. Based on the recommendations of Chapter 1.4., targeted *surveillance* based on an assessment of *risk* factors may be the most efficient *surveillance* approach. Targeted *surveillance* should in particular include *epidemiological units* in close proximity to the *compartment* or those that have a potential epidemiological link with it.

Article 4.X.6.

### **Diagnostic capabilities and procedures**

Officially-designated laboratory facilities should be available for sample testing. All laboratory tests and procedures should comply with the recommendations of the *laboratory* for the specific *disease*. Each laboratory that conducts testing should have systematic procedures in place for rapid reporting of *disease* results to the *Veterinary Authority* or other *Competent Authority*. Where appropriate, results should be confirmed by an OIE Reference Laboratory.

Article 4.X.7.

### **Emergency response and notification**

Early detection, diagnosis and notification of *disease* are critical to minimise the consequences of *outbreaks*.

In the event of suspicion of occurrence of the *disease* for which the *compartment* was defined, the free status of the *compartment* should be immediately suspended. If confirmed, the status of the *compartment* should be immediately revoked and *importing countries* should be notified following the provisions of Chapter 1.1.

In case of an occurrence of any infectious *disease* not present according to the baseline animal health report of the *compartment* referred to in Article 4.2.4., the management of the *compartment* should notify the *Veterinary Authority* or other *Competent Authority*, and initiate a review to determine whether there has been a breach in the biosecurity measures. If a significant breach in biosecurity, even in the absence of *outbreak*, is detected, export certification as a free *compartment* should be suspended. Disease free status of the *compartment* may only be reinstated after the *compartment* has adopted the necessary measures to re-establish the original biosecurity level and the *Veterinary Authority* or other *Competent Authority* re-approves the status of the *compartment*.

In the event of a *compartment* being at risk from a change, in the surrounding area, in the disease situation for which the *compartment* was defined, the *Veterinary Authority* should re-evaluate without delay the status of the *compartment* and any additional biosecurity measures needed to ensure that the integrity of the *compartment* is maintained.

Article 4.X.8.

### **Supervision and control of a compartment**

The authority, organisation, and infrastructure of the *Veterinary Services*, including laboratories, must be clearly documented in accordance with the Chapter on the Evaluation of *Veterinary Services* of the *Aquatic Code*, to provide confidence in the integrity of the *compartment*.

Annex XI (contd)

The *Veterinary Authority* or other *Competent Authority* has the final authority in granting, suspending and revoking the status of a *compartment*. The *Veterinary Authority* or other *Competent Authority* should continuously supervise compliance with all the requirements critical to the maintenance of the *compartment* status described in this Chapter and ensure that all the information is readily accessible to the *importing countries*. Any significant change should be notified to the *importing country*.

---

## CHAPTER 4.1.

## ZONING AND COMPARTMENTALISATION

## Article 4.1.1.

**Introduction**

Given the difficulty of establishing and maintaining freedom from a particular *disease* for an entire country especially for *diseases* whose entry is difficult to control, there may be benefits to one or more Members in establishing and maintaining a *subpopulation* with a distinct aquatic animal health status. *Subpopulations* may be separated by natural or artificial geographical barriers or, in certain situations, by the application of appropriate management practices.

Zoning and compartmentalisation are procedures implemented by a country under the provisions of this chapter to define *subpopulations* of distinct aquatic animal health status for the purpose of *disease* control or *international trade*. Compartmentalisation applies to a *subpopulation* when management practices related to biosecurity are the defining factors, while zoning applies when a *subpopulation* is defined on a geographical basis. In practice, spatial considerations and good management play important roles in the application of both concepts.

This chapter is to assist OIE Members wishing to establish and maintain different *subpopulations*, using the principles of compartmentalisation and zoning. These principles should be applied in accordance with the measures recommended in the relevant *disease* chapter(s). This chapter also outlines a process through which trading partners may recognise such *subpopulations*. This process is best implemented by trading partners through establishing parameters and gaining agreement on the necessary measures prior to *outbreaks of disease*.

Before trade in *aquatic animals* or *aquatic animal products* may occur, an *importing country* needs to be satisfied that its *aquatic animal health status* will be appropriately protected. In most cases, the import regulations developed will rely in part on judgements made about the effectiveness of sanitary procedures undertaken by the *exporting country*, both at its borders and within its *territory*.

In addition to contributing to the safety of *international trade*, zoning and compartmentalisation may assist *disease* control or eradication within Members. Zoning may encourage the more efficient use of resources, and compartmentalisation may allow the functional separation of a *subpopulation* from other domestic or wild *aquatic animals* through biosecurity measures, which a *zone* (through geographical separation) would not achieve. Following an *outbreak of disease*, compartmentalisation may allow a Member be able to take advantage of epidemiological links among *subpopulations* or common practices relating to biosecurity, despite diverse geographical locations, to facilitate *disease* control and/or the resumption of trade.

Zoning and compartmentalisation may not be applicable to all *diseases*, but separate requirements will be developed for each *disease* for which the application of zoning or compartmentalisation is considered appropriate.

To regain the status of a *free zone* or *free compartment* following an *outbreak of disease*, Members should follow the recommendations in the relevant *disease* chapter in the *Aquatic Code*.

Annex XII (contd)

## Article 4.1.2.

**General considerations**

The *Competent Authority* of an *exporting country* that is establishing a *zone* or *compartment* for *international trade* purposes should clearly define the *subpopulation* in accordance with the recommendations in the relevant chapters in the *Aquatic Code*, including those on *surveillance*, and the identification and traceability of *aquatic animals*. The *Competent Authority* of an *exporting country* should be able to explain to the *Competent Authority* of an *importing country* the basis for its claim of a distinct *aquatic animal health status* for the *zone* or *compartment* in such terms.

The procedures used to establish and maintain the distinct *aquatic animal health status* of a *zone* or *compartment* should be appropriate to the particular circumstances and will depend on the epidemiology of the *disease*, environmental factors, *risk* of introduction and establishment of *disease*, and applicable biosecurity measures. The *exporting country* should be able to demonstrate, through detailed documentation supplied to the *importing country*, published through official channels, that it has implemented the recommendations in the *Aquatic Code* for establishing and maintaining such a *zone* or *compartment*.

An *importing country* should recognise the existence of this *zone* or *compartment* when the appropriate measures recommended in the *Aquatic Code* are applied, and the *Competent Authority* of the *exporting country* certifies that this is the case. Note that an *importing country* may adopt a higher level of protection where it is scientifically justified and the obligations referred to in Article 2.1.2. are met. Article 4.1.4. is also relevant.

Where countries share a *zone* or *compartment*, the *Competent Authority* of each country should collaborate to define and fulfil their respective responsibilities.

The *exporting country* should conduct an assessment of the resources needed and available to establish and maintain a *zone* or *compartment* for *international trade* purposes. These include the human and financial resources and the technical capability of the *Competent Authority* (and of the relevant industry, in the case of a *compartment*) including on *disease surveillance* and *diagnosis*.

## Article 4.1.3.

**Principles for defining a zone or compartment, including protection zones**

In conjunction with the above considerations and the definitions of *zone* and *compartment*, the following principles should apply when Members define a *zone* or *compartment*:

1. The extent of a *zone* should be established by the *Competent Authority* on the basis of the definition of *zone* and made public through official channels.
2. A protection zone may be established to preserve the health status of aquatic animals in a free country or zone, from adjacent countries or zones of different aquatic animal health status. Measures should be implemented based on the epidemiology of the disease under consideration to prevent introduction of the pathogenic agent. These measures should include intensified movement control and surveillance and may also include vaccination, special identification, raised awareness or other measures.

The application of these measures can be in the entire free zone or in a defined area within and/or outside the free zone.

23. The factors defining a *compartment* should be established by the *Competent Authority* on the basis of relevant criteria such as management and husbandry practices related to biosecurity, and made public through official channels.

34. *Aquatic animals* belonging to such *subpopulations* need to be recognizable as such through a clear epidemiological separation from other *aquatic animals* and all things presenting a *disease risk*.
45. For a *zone* or *compartment*, the *Competent Authority* should document in detail the measures taken to ensure the identification of the *subpopulation*, for example by means of registration of all the *aquaculture establishments* located in such a *zone* or *compartment* and the establishment and maintenance of its *aquatic animal health status* through a *biosecurity plan*. The measures used to establish and maintain the distinct *aquatic animal health status* of a *zone* or *compartment* should be appropriate to the particular circumstances and will depend on the epidemiology of the *disease*, environmental factors, the *aquatic animal health status* in adjacent areas, applicable biosecurity measures (including movement controls, use of natural and artificial boundaries, the spatial separation of *aquatic animals*, and commercial management and husbandry practices), and *surveillance*.
56. For a *compartment*, the *biosecurity plan* should describe the partnership between the relevant enterprise/industry and the *Competent Authority*, and their respective responsibilities, including the procedures for oversight of the operation of the *compartment* by the *Competent Authority*.
67. For a *compartment*, the *biosecurity plan* should also describe the routine operating procedures to provide clear evidence that the *surveillance* conducted and the management practices are adequate to meet the definition of the *compartment*. In addition to information on *aquatic animal* movements, the *biosecurity plan* should include production and stock records, *feed* sources, traceability, *surveillance* results, visitor logbook, morbidity and mortality history, medications, vaccinations, documentation of training and any other criteria necessary for evaluation of *risk* mitigation. The information required may vary according to the *aquatic animal* species and *disease(s)* under consideration. The *biosecurity plan* should also describe how the measures will be audited to ensure that the *risks* are regularly re-assessed and the measures adjusted accordingly.
78. Thus defined, the *zones* and *compartments* constitute the relevant *subpopulations* for the application of the recommendations in Section 8. to Section 11. of the *Aquatic Code*.

Article 4.1.4.

### **Sequence of steps to be taken in establishing a zone ~~or a compartment~~ and having it recognised for international trade purposes**

There is no single sequence of steps which should be followed in establishing a *zone* ~~or a compartment~~. The steps that the *Competent Authority* of the *importing country* and the *exporting country* choose and implement will generally depend on the circumstances existing within the countries and at their borders, and their trading history. The recommended steps are:

1. For zoning
  - a) The *exporting country* identifies a geographical area, which it considers to contain an *aquatic animal subpopulation* with a distinct aquatic animal health status with respect to a specific *disease/specific diseases*, based on *surveillance*.
  - b) The *exporting country* describes in the *biosecurity plan* for the *zone* the measures which are being, or will be, applied to distinguish such an area epidemiologically from other parts of its *territory*, in accordance with the recommendations in the *Aquatic Code*.
  - c) The *exporting country* provides the above information to the *importing country*, with an explanation of why the area can be treated as an epidemiologically separated *zone* for *international trade* purposes.

Annex XII (contd)

- d) The *importing country* determines whether it accepts such an area as a *zone* for the importation of *aquatic animals* and *aquatic animal products*, taking into account:
  - i) an evaluation of the *exporting country's Competent Authority*;
  - ii) the result of a *risk assessment* based on the information provided by the *exporting country* and its own research;
  - iii) its own *aquatic animal* health situation with respect to the *disease(s)* concerned; and
  - iv) other relevant OIE standards.
- e) The *importing country* notifies the *exporting country* of the result of its determination and the underlying reasons, within a reasonable period of time, being either:
  - i) recognition of the *zone*;
  - ii) request for further information; or
  - iii) rejection of the area as a *zone* for *international trade* purposes.
- f) An attempt should be made to resolve any differences over the recognition of the *zone*, either in the interim or finally, by using an agreed mechanism to reach consensus (such as the OIE dispute settlement mechanism).
- g) The *importing country* and the *exporting country* should enter into a formal agreement recognising the *zone*.

2. For compartmentalisationRefer to Chapter 4.X.

- a) ~~Based on discussions with the relevant enterprise/industry, the *exporting country* identifies a compartment of one or more *aquaculture establishments* or other premises that operate under common management practices related to biosecurity, and which contains an identifiable *aquatic animal subpopulation* with a distinct aquatic animal health status with respect to a specific *disease/specific diseases*; the *exporting country* describes how this status is maintained through a partnership between the relevant enterprise/industry and the *Competent Authority* of the *exporting country*.~~
- b) ~~The *exporting country* examines the compartment's *biosecurity plan* and confirms through an audit that:~~
  - i) ~~the compartment is epidemiologically closed throughout its routine operating procedures as a result of effective implementation of its *biosecurity plan*; and~~
  - ii) ~~the *surveillance* programme in place is appropriate to verify the status of such *aquaculture establishment(s)* with respect to such *disease(s)*.~~
- e) ~~The *exporting country* describes the compartment, in accordance with the recommendations in the *Aquatic Code*.~~
- d) ~~The *exporting country* provides the above information to the *importing country*, with an explanation of why such an enterprise can be treated as an epidemiologically separated compartment for *international trade* purposes.~~



Annex XII (contd)

- e) ~~The importing country determines whether it accepts such an enterprise as a compartment for the importation of aquatic animals and aquatic animal products, taking into account:~~
- ~~i) an evaluation of the exporting country's Competent Authority;~~
  - ~~ii) the result of a risk assessment based on the information provided by the exporting country and its own research;~~
  - ~~iii) its own aquatic animal health situation with respect to the disease(s) concerned; and~~
  - ~~iv) the relevant OIE standards.~~
- f) ~~The importing country notifies the exporting country of the result of its examination and the underlying reasons, within a reasonable period of time, being either:~~
- ~~i) recognition of the compartment;~~
  - ~~ii) request for further information; or~~
  - ~~iii) rejection of such an enterprise as a compartment for international trade purposes.~~
- g) ~~An attempt should be made to resolve any differences over the recognition of the compartment, either in the interim or finally, by using an agreed mechanism to reach consensus (such as the OIE dispute settlement mechanism).~~
- h) ~~The importing country and the exporting country should enter into a formal agreement recognising the compartment.~~

---

-----  
- text deleted



## CHAPTER 4.5.

**CONTROL OF HAZARDS OF AQUATIC ANIMAL  
HEALTH HAZARDS AND PUBLIC HEALTH  
IMPORTANCE IN AQUATIC ANIMAL FEEDS**

## Article 4.5.1.

**Introduction**

One of the key objectives of the *Aquatic Code* is to help OIE Members trade safely in *aquatic animals* and *aquatic animal products* by developing relevant *aquatic animal* health measures. These recommendations address *aquatic animal* health hazards in *aquatic animal feed*. A key objective is to prevent the spread, via *aquatic animal feed*, of *diseases* from an infected country, *zone* or *compartment* to a *free country*, a *free zone* or a *free compartment*.

~~These recommendations do not address food safety issues in detail as this is not within the mandate of the *Aquatic Code*.~~

These recommendations should be read in conjunction with relevant recommendations of the OIE *Terrestrial Animal Health Code* ~~(under study)~~. The Food and Agriculture Organization of the United Nations (FAO) has published recommendations relevant to terrestrial and *aquatic animal feed* (Technical Guidelines for Responsible Fisheries – Aquaculture Development: 1. Good aquaculture feed manufacturing practice. FAO 2001; Draft Good Practices for the Animal Feed Industry – Implementing the Codex Alimentarius' Code of Practice on Good Animal Feeding, IFIF/FAO [In preparation]) and there is a Codex Alimentarius Commission (CAC) standard (Code of Practice on Good Animal Feeding [CAC/RCP 54-2004]). OIE Members are encouraged to consult these publications.

Key considerations relevant to *aquatic animal feed* are as follows:

1. Concentration of *aquaculture establishments* heightens the *risk* of *disease* transmission, whether the pathogen enters the culture system via *feed* or other means.
2. For many *aquatic animal* species, predation (including cannibalism) is their natural way of feeding in their natural habitat.
3. Historically, animal proteins used in *feed* were mainly sourced from the marine environment, due to the nutritional needs of *aquatic animals* and for reasons of economy. This practice increases the *risk* of *disease* transmission, especially when *aquatic animals* are fed live or whole *aquatic animals* of the same or related species. There are many examples of this type of practice, e.g. early stage crustaceans fed on *Artemia* species and *aquaculture* tuna fed on whole wild caught fish.
4. The usage of *feed* in moist form (moisture content equal to or greater than 70%), semi-moist form (moisture content between 15 and 70%), and dry form (a moisture content equal to or less than 15%) implies different levels of *risk* due to the processing applied to the *feed*.
5. With the increasing number of species being farmed (especially marine finfish), the use of *live feed* and moist feed has increased. It is likely that these industries will in future use formulated *feed* as appropriate technologies are developed.

Annex XIII (contd)

6. Hazards may be transmitted from *feed* to *aquatic animals* via direct or indirect means. Direct transmission occurs when the cultured species consumes *feed* containing a pathogenic agent (e.g. shrimp larvae consuming rotifer ~~infected~~ contaminated with white spot syndrome virus) while indirect transmission refers to pathogens in *feed* entering the aquatic environment or infecting non target species, and thereby establishing a mechanism for indirect *infection* of the species of commercial interest. Pathogens that are less host-specific (e.g. white spot syndrome virus, *Vibrio* species) present a greater *risk* of indirect transmission as they can establish reservoirs of *infection* in multiple species.
7. As new species become the subject of *aquaculture*, new pathogens emerge in association with these hosts. The expression of *disease* may be facilitated by culturing species under intensive and novel conditions. Also, it is necessary to conduct research and develop new *feed* (and *feed ingredients*) that are appropriate to the species and its culture system. As more and more *aquatic animal* species are being cultured, it is difficult to make recommendations for all *disease agent*/host species combinations.

Article 4.5.2.

**Scope**

These recommendations document *risk* mitigation measures, including traceability and certification, to deal with *aquatic animal* health *risks* associated with trade in *aquatic animal feed* and *feed ingredients*. They recommend the control of hazards through adherence to recommended practices during the production (harvest, handling, storage, processing and distribution) and use of both commercial and on-farm produced *feed* (and *feed ingredients*) for *aquatic animals*. Hazards include pathogens that cause *OIE-listed diseases* and other agents that cause an adverse effect on animal and/or public health. While *aquatic animals* grown for food are the main focus, the same principles apply to *feed* for *aquatic animals* used for other purposes.

Article 4.5.3.

**Definitions****Hazard**

~~means a biological, chemical or physical agent in a *feed* or a *feed ingredient* with the potential to cause an adverse effect on animal or public health.~~

Article 4.5.4.

**General principles**1. Roles and responsibilities

The *Competent Authority* has the legal power to set and enforce regulatory requirements related to animal *feed*, and has final responsibility for verifying that these requirements are met. The *Competent Authority* may establish regulatory requirements for relevant parties, including requirements to provide information and assistance. Refer to Chapter 3.1. of the *Aquatic Code*.

It is a particular responsibility of the *Competent Authority* to set and enforce the regulatory requirements pertaining to the use of veterinary drugs, *aquatic animal disease* control and the food safety aspects that relate to the management of live *aquatic animals* on farm.

Those involved in the production and use of animal *feed* and *feed ingredients* have the responsibility to ensure that these products meet regulatory requirements. All personnel involved in the harvest, manufacture, storage and handling of *feed* and *feed ingredients* should be adequately trained and aware of their role and responsibility in preventing the spread of hazards. Appropriate *contingency plans* should be developed in case of a *feed-borne outbreak of disease*. Equipment for producing, storing and transporting *feed* should be kept clean and maintained in good working order.

Private veterinarians and others (e.g. laboratories) providing specialist services to producers and to the *feed* industry may be required to meet specific regulatory requirements pertaining to the services they provide (e.g. *disease* reporting, quality standards, transparency).

## 2. Regulatory standards for feed safety

All *feed* and *feed ingredients* should meet regulatory standards for *feed* safety. In defining limits and tolerances for hazards, scientific evidence, including the sensitivity of analytical methods, and on the characterisation of *risks*, should be taken into account.

## 3. Risk analysis

Internationally accepted principles and practices for *risk analysis* (see Section 2. of the *Aquatic Code* and relevant Codex texts) should be used in developing and applying the regulatory framework.

A generic *risk analysis* framework should be applied to provide a systematic and consistent process for managing hazards.

## 4. Good practices

Where national guidelines exist, good *aquaculture* practices and good manufacturing practices (including good hygienic practices) should be followed. Countries without such guidelines are encouraged to develop them.

Where appropriate, Hazard Analysis and Critical Control Point (HACCP; as defined in the Annex to the Recommended International Code of Practice on General Principles of Food Hygiene [CAC/RCP 1-1969]) principles should be followed to control hazards that may occur in *feed*.

## 5. Relationship between prions and aquatic animal species

Scientific knowledge is lacking on the relationship between prions and *aquatic animal* species. There is no evidence to suggest that the use of terrestrial animal by-products as ingredients in *aquatic animal feed* gives rise to *risks* in respect of prion diseases. More scientific information is desirable to enable *aquaculture* industries to utilise more terrestrial animal by-products as a means of reducing dependency on aquatic protein and lipid sources.

## 6. Bioaccumulation

Heavy metals, dioxins and polychlorinated biphenyls (PCB) persist in fatty tissues and therefore tend to *accumulate* through the food chain.

Annex XIII (contd)7. Geographic and environmental considerations

Aquatic and terrestrial harvest areas for *feed* should not be located in proximity to sources of animal health or food safety hazards. Where this cannot be avoided, preventive measures should be *applied* to control *risk*. The same recommendations apply for the processing of *feed* and the location of *aquaculture establishments*.

*Aquatic animal health considerations* include factors such as disease status, location of quarantined premises, existence of processing plants without proper biosecurity measures and the existence of *zones/ compartments* of specified health status.

Public health considerations include factors such as industrial operations and waste treatment plants that generate pollutants and other hazardous products. The potential accumulation of pollutants in the *food chain* through *feed* needs to be considered.

8. Zoning and compartmentalisation

*Feed* is an important components of biosecurity and needs to be considered when defining a *compartment* or *zone* in accordance with Chapter 4.1. of the *Aquatic Code*.

9. Sampling and analysis

Sampling and analytical protocols for *feed* should be based on scientific principles and procedures, and OIE standards where applicable.

10. Labelling

Labelling should be clear and informative on how the *feed* and *feed ingredients* should be handled, stored and used and should comply with regulatory requirements. Labelling should provide for trace-back.

See Section 4.2. of the Codex Code of Practice on Good Animal Feeding (CAC/RCP 54-2004).

11. Design and management of inspection programmes

In meeting animal and public health objectives prescribed in national legislation or required by *importing countries*, *Competent Authorities* contribute through the direct performance of some tasks or through the auditing of animal and public health activities conducted by other agencies or the private sector.

Operators in the *feed* and *feed ingredients* business and other relevant industries should implement procedures to ensure compliance with regulatory standards for harvest, handling, storage, processing, distribution and use of *feed* and *feed ingredients*. Operators have the primary responsibility for implementing systems for process control. Where such systems are applied, the *Competent Authority* should verify that they meet all regulatory requirements.

12. Assurance and certification

*Competent Authorities* are responsible for providing assurances domestically and to trading partners that regulatory requirements have been met.

### 13. Hazards associated with aquatic animal feed

#### a) Biological hazards

Biological hazards that may occur in *feed* and *feed ingredients* include agents such as bacteria, viruses, fungi and parasites. The scope of these recommendations covers *OIE-listed diseases* and other agents that cause an adverse effect on animal and/or public health.

#### b) Chemical hazards

Chemical hazards that may occur in *feed* and *feed ingredients* include naturally occurring chemicals (such as mycotoxins, gossypol and free radicals), industrial and environmental contaminants (such as heavy metals, dioxins and PCBs), residues of veterinary drugs and pesticides and radionuclides.

#### c) Physical hazards

Physical hazards that may occur in *feed* and *feed ingredients* include foreign objects (such as pieces of glass, metal, plastic or wood).

### 14. Cross-contamination

~~It is important to avoid cross-contamination during the manufacture, storage, distribution (including transport) and the use of *feed* and *feed ingredients*. Appropriate provisions should be included in the regulatory framework. Scientific evidence, including the sensitivity of analytical methods and on the characterisation of *risks*, should be drawn upon in developing this framework.~~

It is necessary that the prevention of contamination during the manufacture, storage, distribution (including transport) and the use of *feed* and *feed ingredients* and relevant provisions should be included in current regulations and standards. Scientific evidence, including the sensitivity of analytical methods and on the characterisation of *risks*, should be drawn upon in developing this framework.

Procedures, such as flushing, sequencing and physical clean-out, should be used to reduce the likelihood of contamination between batches of *feed* or *feed ingredients*.

Procedures such as flushing, sequencing and physical clean-out should be used to avoid cross-contamination between batches of *feed* or *feed ingredients*. National regulations should be followed in order to avoid the use of unauthorised *feed ingredients* with a *risk* of cross-contamination.

### 15. Antimicrobial resistance

Concerning the use of antimicrobials in animal *feed* refer to Section X.X.X. of the *Aquatic Code* (under study).

### 16. Management of information

The *Competent Authority* should establish requirements for the provision of information by the private sector in accordance with the regulatory framework.

Annex XIII (contd)

The private sector should maintain records, in a readily accessible form, on the production, distribution, importation and use of *feed* and *feed ingredients*. These records are required to facilitate the prompt trace-back of *feed* and *feed ingredients* to the immediate previous source, and trace-forward to the next/subsequent recipients, to address *aquatic animal* health and/or public health concerns. The private sector should provide information to the *Competent Authority* in accordance with the regulatory framework.

Animal identification (in the case of *aquatic animals* this will normally be on a group basis) and traceability are tools for addressing animal health and food safety *risks* arising from animal *feed* (see ~~Section 3.5, Chapters 4.1. and 4.2.~~ of the OIE *Terrestrial Animal Health Code*, Section 4.3 of CAC/RCP 54-2004).

~~Article 4.5.5.~~**Pathogens in feed**

~~1. Pathogens can be introduced into *feed* in the following ways:~~

- ~~a) via the harvest of infected *aquatic animals*;~~
- ~~b) during storage, processing and transport, due to poor hygienic practices, the presence of pests, or residues of previous batches of *feed* remaining in processing lines, *containers* or transport *vehicles*.~~

~~2. *Aquatic animals* can be exposed to pathogens in *feed* in the following ways:~~

~~a) Direct exposure~~

~~The use of unprocessed *feed* derived from *aquatic animals* to feed *aquatic animals* presents a direct route of exposure, particularly when feeding whole *aquatic animals* and unprocessed products of *aquatic animals* to animals of the same species. For example feeding salmonid offal to salmonids or feeding rotifers or *Artemia* species to crustaceans presents a heightened *risk* of *disease* transmission.~~

~~b) Indirect exposure~~

~~Pathogens in *feed* may be transmitted to *aquatic animals* in *aquaculture* and wild *aquatic animals* via contamination of the environment or *infection* of non target species.~~

~~Article 4.5.6.~~**Chemical agents in feed**

{under study}

~~Article 4.5.7.~~**Physical agents in feed**

{under study}

~~Article 4.5.8.~~**Recommended approaches to risk mitigation**



## 1. Commodities

### a) Safe commodities

The following *commodities* undergo extensive processing such as heat treatment, acidification, extrusion and extraction. There is a negligible *risk* that pathogens will survive in such products if they have been produced in accordance with normal commercial practice:

- i) fish oil;
- ii) crustacean oil;
- iii) fish solubles (a by-product of the fish oil production system, comprising the product remaining when water is drawn off [evaporated] from the residual aqueous phase);
- iv) fish *meal*;
- v) crustacean *meal*;
- vi) squid *meal* and squid liver-*meal*;
- vii) bivalve *meal*;
- viii) finished *feed* (e.g. flake, pelleted and extruded *feed*).

For these *commodities*, *Competent Authorities* should not require conditions in relation to *aquatic animal diseases*, regardless of the *aquatic animal* health status of the *exporting country, zone or compartment*.

### b) Other commodities

*Competent Authorities* should consider the following *risk* mitigation measures:

- i) sourcing *feed* and *feed ingredients* from a *disease free country, free zone or free compartment*; or
- ii) confirmation (e.g. by testing) that pathogens are not present in the *commodity*; or
- iii) treatment (e.g. by heat or acidification) of the *commodity* using a method approved by the *Competent Authority* to inactivate pathogens; or
- iv) use of *feed* only in populations that are not susceptible to the pathogen(s) in question and where *aquatic animals* that are susceptible to the pathogen(s) in question will not come into contact with the *feed* or its waste products.

In addition, *risks* associated with the disposal of effluents and waste material from *feed* processing plants and *aquaculture establishments* should be considered.

Annex XIII (contd)

## c) Whole fish (fresh or frozen)

The practice of trading fresh or frozen whole marine fish for use as *aquatic animal feed* presents a *risk* of introducing *diseases* into populations. *Risk* mitigation measures include sourcing fish only from stocks where there is no evidence of *infection* with any of the *OIE-listed diseases* or treatments that inactivate *aquatic animal* pathogens.

2. Feed production

To prevent contamination by pathogens during production, storage and transport of *feed* and *feed ingredients*:

- a) flushing, sequencing or physical clean-out of manufacturing lines and storage facilities should be performed between batches as appropriate;
- b) buildings and equipment for processing and transporting *feed* and *feed ingredients* should be constructed in a manner that facilitates hygienic operation, maintenance and cleaning and prevents contamination;
- c) in particular, *feed* manufacturing plants should be designed and operated to avoid cross-contamination between batches;
- d) processed *feed* and *feed ingredients* should be stored separately from unprocessed *feed ingredients*, under appropriate storage conditions;
- e) *feed* and *feed ingredients*, manufacturing equipment, storage facilities and their immediate surroundings should be kept clean and pest control programmes should be implemented;
- f) measures to inactivate pathogens, such as heat treatment or the addition of authorised chemicals, should be used where appropriate. Where such measures are used, the efficacy of treatments should be monitored at appropriate stages in the manufacturing process;
- g) labelling should provide for the identification of *feed* and *feed ingredients* as to the batch/lot and place and date of production. To assist in tracing *feed* and *feed ingredients* as may be required to deal with animal disease incidents, labelling should provide for identification by batch/lot and place and date of production.

3. Importing countries

*Competent Authorities* should consider the following measures:

- a) imported *feed* and *feed ingredients* should be delivered to *feed* manufacturing plants or *aquaculture* facilities for processing and use under conditions approved by the *Competent Authority*;
- b) effluent and waste material from *feed* manufacturing plants and *aquaculture* facilities should be managed under conditions approved by the *Competent Authority*, including, where appropriate, treatment before discharge into the aquatic environment;
- c) *feed* that is known to contain pathogens should only be used in a *zone* or *compartment* that does not contain species susceptible to the *disease* in question;

- d) the importation of raw unprocessed *feed* derived from *aquatic animals* to feed *aquatic animal* species should be avoided where possible.

Article 4.5.9.

### **Certification procedures for feeds and feed ingredients of aquatic animal origin**

When importing *feed* and *feed ingredients* of *aquatic animal* origin other than those mentioned in point 1a of Article 4.5.8., the *Competent Authority* of the *importing country* should require that the consignment be accompanied by an *international aquatic animal health certificate* issued by the *Competent Authority* of the *exporting country* (or a *certifying official* approved by the *importing country*).

This certificate should certify:

1. that *feed* and *feed ingredients* of *aquatic animal* origin were obtained from a country, *zone* or *compartment* that is free from relevant *aquatic animal diseases*; or
2. that *feed* and *feed ingredients* of *aquatic animal* origin were tested for relevant *aquatic animal diseases* and shown to be free of these *diseases*; or
3. that *feed* and *feed ingredients* of *aquatic animal* origin have been processed to ensure that they are free of relevant *aquatic animal diseases*.

Specific provisions for *OIE-listed diseases* may be found in relevant *disease* chapters of the *Aquatic Code*.

Article 4.5.10.

### **Risk pathways for ~~chart of~~ pathogen transmission and contamination through harvest, manufacture and use of aquatic animal feed**

1. Pathogens can be introduced into *feed* in the following ways:

- a) via the harvest of infected *aquatic animals*;
- b) during storage, processing and transport, due to poor hygienic practices, the presence of pests, or residues of previous batches of *feed* remaining in processing lines, *containers* or transport *vehicles*.

2. *Aquatic animals* can be exposed to pathogens in *feed* in the following ways:

a) Direct exposure

The use of unprocessed *feed* derived from *aquatic animals* to feed *aquatic animals* presents a potential direct route of exposure. For example feeding salmonid offal to salmonids presents a heightened *risk* of *disease* transmission because tissue from a *susceptible species* is being fed to a *susceptible species*.

b) Indirect exposure

Pathogens in *feed* may be transmitted to *aquatic animals* in *aquaculture* and wild *aquatic animals* via contamination of the environment or *infection* of non-target species.

Annex XIII (contd)

Figure 1 illustrates the possible pathways for transmission of pathogens within the *feed* production and utilisation process.

*Feed ingredients* of aquatic origin used in *aquaculture* can be a source of pathogens (viruses, bacteria and parasites) to cultured *aquatic animal* species. In *aquaculture establishments* pathogens in *feed* can infect the animals directly (via consumption of *feed*) or indirectly via environmental sources. *Live feed* and moist *feed* are more likely to contain pathogens because their ingredients are either in a raw state or subject to minimal treatment.

*Feed* and *feed ingredients* harvested from infected countries, *zones* or *compartments* may have a high pathogen load. *Feed* and *feed ingredients* from these sources should be processed (e.g. using heat or chemical treatments) to reduce, or eliminate, the pathogen load. After processing care should be taken to avoid post processing contamination during storage and transportation of these *commodities*. For example, when two or more batches of *ingredients* of different sanitary status are handled, stored and/or transported together without appropriate biosecurity measures, there is a *risk* of cross-contamination of the *feed*.

An *aquaculture* facility can also be a source of pathogens in *aquatic animal feed*. For example, *feed* can be contaminated with pathogens through poor hygiene practices at an infected *aquaculture establishment*. If the *feed* is redistributed from the *aquaculture* facility to the manufacturing facility for recycling, or distributed to another farm, pathogens can be transferred to other *aquaculture establishments*.

Figure 1: **Risk chart of pathogen transmission and contamination through harvest, manufacture and use of aquatic animal feed**

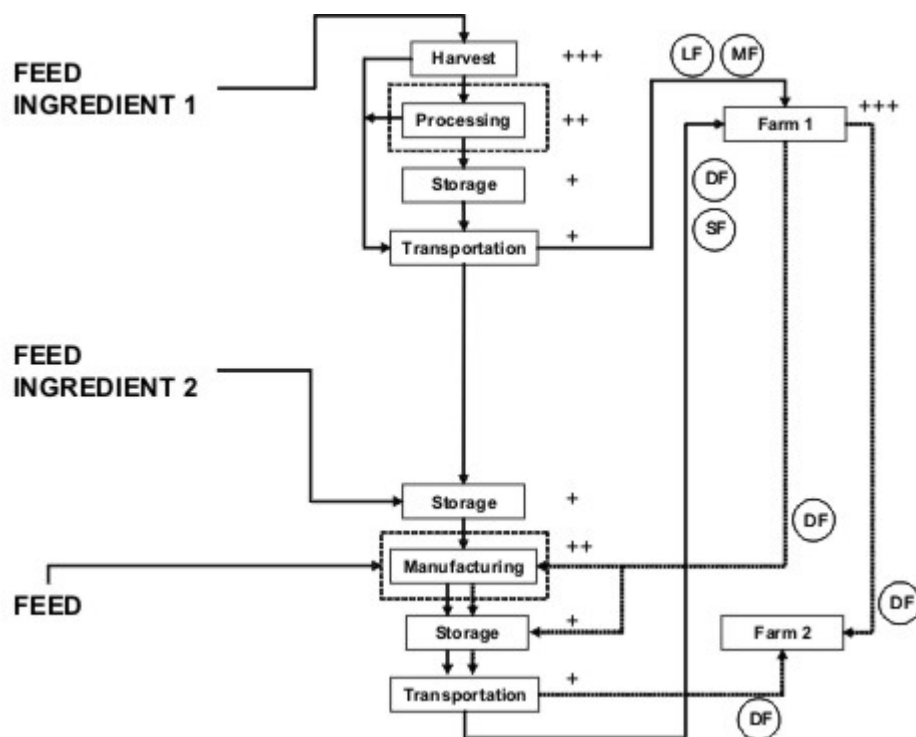

LF	Live feed	
MF	Moist feed	
SF	Semi-moist feed	——> Possibility for risk reduction
DF	Dry feed	
+++	High risk of pathogen presence	
++	Moderate risk of pathogen presence	..... Redistribution or recycling of finished feed
+	Low risk of pathogen presence	

-----  
- text deleted



## CHAPTER 5.1.

GENERAL OBLIGATIONS  
RELATED TO CERTIFICATION

## Article 5.1.1.

A combination of factors should be taken into account to facilitate *international trade* in *aquatic animals* and *aquatic animal products*, without incurring unacceptable *risks* to human and *aquatic animal* health.

Because of differences between countries in their *aquatic animal* health situations, various options are offered by the *Aquatic Code*. The *aquatic animal* health situation in the *exporting country*, in the *transit country* or *countries* and in the *importing country* should be considered before determining the requirements for trade. To maximise harmonisation of the *aquatic animal* health aspects of *international trade*, *Competent Authorities* of OIE Members should base their import requirements on the OIE standards.

These requirements should be included in the certificates drawn up in accordance with the model *international aquatic animal health certificates* provided for in Chapter 5.10. of the *Aquatic Code*.

Certification should be exact and concise, and should clearly address the requirements of the *importing country*. For this purpose, prior consultation between *Competent Authorities* of *importing* and *exporting countries* may be necessary.

The certification requirements should not include conditions for diseases that are not transmitted by the commodity concerned. There should only be one signing certifying official for one certificate.

When officials of a *Competent Authority* wish to visit another country for matters of professional interest to the *Competent Authority* of the other country, the latter should be informed prior to any such visit. This visit should be mutually agreed upon between *Competent Authorities*.

## Article 5.1.2.

**Responsibilities of the importing country**

1. The import requirements included in the *international aquatic animal health certificate* should assure that *commodities* introduced into the *importing country* comply with OIE standards. *Importing countries* should restrict their requirements to those necessary to achieve the national appropriate level of protection. If these are stricter than the OIE standards, they should be based on an import *risk analysis*.
2. The *international aquatic animal health certificate* should not include requirements for the exclusion of *disease agents* or *aquatic animal diseases* that are present in the *importing country* and are not subject to any official control programme, except when the strain of the *disease agent* in the *exporting country* is of significantly higher pathogenicity and/or has a larger host range. The measures imposed on imports to manage the *risks* posed by a *disease agent* or *aquatic animal disease* should not require a higher level of protection than that provided by measures applied as part of the official control programme operating within the *importing country*.
3. The *international aquatic animal health certificate* should not include measures against *disease agents* or *diseases* that are not OIE listed, unless the *importing country* has demonstrated through an import *risk analysis*, carried out in accordance with Section 2., that the *disease agent* or *disease* poses a significant *risk* to the *importing country*.

Annex XIV (contd)

4. The transmission by the *Competent Authority* of certificates or the communication of import requirements to persons other than the *Competent Authority* of another country necessitates that copies of these documents be also sent to the *Competent Authority*. This important procedure avoids delays and difficulties that may arise between traders and *Competent Authorities* when the authenticity of the certificates or permits is not established.

The transmission of this information is the responsibility of *Competent Authorities* of the *exporting country*. However, it can be issued by private sector *veterinarians* at the place of origin of the *commodities* when this practice is the subject of appropriate approval and authentication by *Competent Authorities*.

5. Situations may arise that result in changes to the consignee, identification of the means of transportation, or *frontier post* after a certificate is issued. If it is determined that these do not change the *aquatic animal* health or public health status of the consignment, then they should not prevent the acceptance of the certificate.

## Article 5.1.3.

**Responsibilities of the exporting country**

1. An *exporting country* should, on request, supply the following to *importing countries*:
  - a) information on the *aquatic animal* health situation and national *aquatic animal* health information systems to determine whether that country is free or has *zones* or *compartments* free from *OIE-listed diseases*, and on the pathway followed to achieve disease freedom i.e. absence of susceptible species or targeted surveillance, including the regulations and procedures in force to maintain the free status;
  - b) regular and prompt information on the occurrence of *OIE-listed diseases*;
  - c) details of the country's ability to apply measures to control and prevent *OIE-listed diseases*;
  - d) information on the structure of the *Competent Authority* and the authority that they exercise;
  - e) technical information, particularly on biological tests and vaccines applied in all or part of the country.
2. *Competent Authorities* of *exporting countries* should:
  - a) have official procedures for the authorisation of *certifying officials*, defining their functions and duties as well as conditions of oversight and accountability, ~~covering~~ including possible suspension and termination of the ~~appointment~~ authorisation;
  - b) ensure that relevant instructions and training are provided to *certifying officials*;
  - c) monitor the activities of the *certifying officials* to verify their integrity and impartiality.
3. The *Competent Authority* of the *exporting country* is ultimately accountable for certification used in *international trade*.

## Article 5.1.4.

**Responsibilities in case of an incident related to importation**



1. *International trade* involves a continuing ethical responsibility. Therefore, if within a reasonable period subsequent to an export taking place, the *Competent Authority* becomes aware of the appearance or reappearance of a *disease* that has been specifically included in the *international aquatic animal health certificate* or other *disease* of potential epidemiological importance to the *importing country* there is an obligation for the *Competent Authority* to notify the *importing country*, so that the imported *commodities* may be inspected or tested and appropriate action be taken to limit the spread of the *disease* should it have been inadvertently introduced.
  
2. If a *disease* condition appears in imported *aquatic animals* within a reasonable period after importation, the *Competent Authority* of the *exporting country* should be informed so as to enable an investigation to be made, because this may be the first available information on the occurrence of the *disease* in a previously free *aquatic animal* population. The *Competent Authority* of the *importing country* should be informed of the result of the investigation because the source of *infection* may not be in the *exporting country*.
  
3. If, after importation of *commodities*, a *disease* condition appears, within a reasonable period after importation, in *aquatic animals* in the *importing country*, the *Competent Authority* of the *exporting country* should be informed so as to enable an investigation to be made, because this may be the first available information on the occurrence of the *disease* in a previously free *aquatic animal* population. The *Competent Authority* of the *importing country* should conduct trace back investigations because the source of *disease* may not be in the *exporting country*.
  
4. In case of suspicion, on reasonable grounds, that an *international aquatic animal health certificate* may be fraudulent, the *Competent Authority* of the *importing country* and *exporting country* should conduct an investigation. Consideration should also be given to notifying any third country(ies) that may have been implicated. All associated consignments should be kept under official control, pending the outcome of the investigation. *Competent Authorities* of all countries involved should fully cooperate with the investigation. If the *international aquatic animal health certificate* is found to be fraudulent, every effort should be made to identify those responsible so that appropriate action can be taken according to the relevant legislation.

---

-----

— text deleted



## CHAPTER 5.2.

## CERTIFICATION PROCEDURES

## Article 5.2.1.

**Protection of the professional integrity of the certifying official**

Certification should be based on the highest possible ethical standards, the most important of which is that the professional integrity of the *certifying official* must be respected and safeguarded.

It is essential ~~not~~ to include in ~~the any~~ requirements ~~additional specific matters that cannot~~ only those specific statements that can be accurately and honestly signed by a *certifying official*. For example, these requirements should not include certification of an area as being free from *diseases* that are not notifiable in that country, or the occurrence of which the signing *certifying official* is not necessarily informed about. ~~Equally, it is unacceptable to ask for certification for events that will take place after the document is signed is unacceptable~~ when these events are not under the direct control and supervision of the signing *certifying official*.

## Article 5.2.2.

**Certifying officials**

*Certifying officials* should:

1. be authorised by the *Competent Authority* of the *exporting country* to sign *international aquatic animal health certificates*;
2. only certify matters that are within their own knowledge at the time of signing the certificate, or that have been separately attested by another competent party authorised ~~approved~~ by the *Competent Authority*;
3. sign only at the appropriate time certificates that have been completed fully and correctly; where a certificate is signed on the basis of supporting documentation, the *certifying official* should have verified or be in possession of that documentation before signing;
4. have no conflict of interest in the commercial aspects of the *aquatic animals* or *aquatic animal products* being certified and be independent from the commercial parties.

## Article 5.2.3.

**Preparation of international aquatic animal health certificates**

Certificates should be drawn up in accordance with the following principles:

1. Certificates should be designed so as to minimise the potential for fraud including use of a unique identification number, or other appropriate means to ensure security. Paper certificates should bear the signature of the certifying official and the official identifier (stamp) of the issuing *Competent Authority*. Each page of a multiple page certificate should bear the unique certificate number and a number indicating the number of the page out of the total number of pages. Electronic certification procedures should include equivalent safeguards.

Annex XV (contd)

2. Certificates ~~They~~ should be written ~~in~~ using terms that are ~~as~~ simple, unambiguous and as easy to understand as possible, without losing their legal meaning.
3. If so required, certificates ~~they~~ should be written in the language of the *importing country*. In such circumstances, they should also be written in a language understood by the *certifying official*.
4. Certificates ~~They~~ should require appropriate identification of *aquatic animals* and *aquatic animal products* except where this is impractical (e.g. eyed eggs).
5. Certificates ~~They~~ should not require a *certifying official* to certify matters that are outside his/her knowledge or that he/she cannot ascertain and verify.
6. Where appropriate, when presented to the certifying veterinarian, certificates ~~they~~ should be accompanied, ~~when presented to the certifying official,~~ by notes of guidance indicating the extent of enquiries, tests or examinations expected to be carried out before the certificate is signed.
7. ~~Their~~ text of a certificate should not be amended except by deletions that must be signed and stamped by the *certifying official*.
8. The signature and stamp must be in a colour different to that of the printing of the certificate. The stamp may be embossed instead of being a different colour.
9. Only original certificates should be accepted by the *importing country*.
10. Replacement certificates may be issued by a *Competent Authority* to replace original certificates that have been, for example, lost, damaged, contain errors, or where the original information is no longer correct. These replacements should be provided by the issuing authority and be clearly marked to indicate that they are replacing the original certificate. A replacement certificate should reference the number and the issue date of the certificate that it supersedes. The superseded certificate should be cancelled and where possible, returned to the issuing authority.

Article 5.2.4.

**Electronic certification**

1. Certification may be provided by electronic documentation sent directly from the *Competent Authority* of the *exporting country* to the *Competent Authority* of the *importing country*. Normally, such systems also provide an interface with the commercial organisation marketing the *commodity* for provision of information to the certifying authority. The *certifying official* must have access to all information such as laboratory results and *aquatic animal* identification data.
2. Electronic certificates should carry the same information as conventional certificates.
3. The *Competent Authority* must have in place systems for the security of electronic certificates against access by unauthorised persons or organisations.
4. The *certifying official* must be officially responsible for the secure use of his/her electronic signature.

---

-----  
- text deleted

## CHAPTER 5.10.

**MODEL HEALTH CERTIFICATES  
FOR INTERNATIONAL TRADE IN  
LIVE AQUATIC ANIMALS AND  
PRODUCTS OF AQUATIC ANIMAL ORIGIN**

Article 5.10.1.

**Notes for guidance on the health certificates for international trade in live aquatic animals and products of aquatic animal origin**

1. General

Please complete the certificate on paper in capital letters. To confirm an option, mark the box with a cross (X). Ensure that no portion of certificate is left blank in a manner that would allow it to be amended. Non-applicable fields may be crossed out.

2. Part I. Details of dispatched consignment

Country:	Name of the country that issues the certificate.
Box I.1.	Name and full address of the natural or legal entity dispatching the consignment. Information on telephone and fax numbers or e-mail address is recommended.
Box I.2.	The certificate reference number is the number used by the Competent Authority of the country to identify the certificate.
Box I.3.	Name of the Competent Authority.
Box I.4.	Name and full address of the natural or legal entity to whom the consignment is destined at the time the certificate is issued.
Box I.5.	Name of the country from which the live aquatic animals <del>or gametes</del> are being exported. For aquatic animal products, name the country(ies) where the finished products were produced, manufactured or packed. "ISO code" refers to the international standard two-letter code (ISO 3166-1 Alpha-2 Code) for a country produced by the International Organization for Standardization.
Box I.6.	Name of the zone or compartment of origin, if relevant, in part II of the certificate.
Box I.7.	Name of the country of destination. "ISO code" refers to the international standard two-letter code (ISO 3166-1 Alpha-2 Code) for a country produced by the International Organization for Standardization.
Box I.8.	Name of the zone or compartment of destination, if relevant, in part II of the certificate.
Box I.9.	Name and full address of the place(s) from which the live aquatic animals or aquatic animal products are being exported; and official approval or registration number when required. For live aquatic animals <del>and gametes</del> : the establishment(s) or place of capture. For products of aquatic animal origin: the premises from which the products are to be dispatched.

## Annex XVI (contd)

Box I.10.	Name of the place from which the live aquatic animals or aquatic animal products are being shipped (this will be a land, sea or airport).
Box I.11.	Date of departure. For live aquatic animals include the expected time of departure.
Box I.12.	<p>Details of the means of transport.</p> <p>Identification of the means of transport at the time the certificate is issued: for air transport, the flight number; for maritime transport, the name of the vessel; for rail transport, the number of the train and the wagon and for road transport, the registration number of the road vehicle and the number of the trailer where used.</p>
Box I.13.	Name of expected border post and, if available, its UN/LOCODE (refer to the United Nations Code for Trade and Transport Locations).
Box I.14.	CITES permit number(s) if the commodity concerns species listed in the Convention on International Trade in Endangered Species of Wild Fauna and Flora.
Box I.15.	Describe the commodity or use the titles as they appear in the Harmonised System of the World Customs Organization.
Box I.16.	Heading or HS Code of the Harmonized System set up by the World Customs Organization.
Box I.17.	<p>Total quantity or weight of the commodity.</p> <p>For live aquatic animals <del>and gametes</del> give the total count or weight.</p> <p>For aquatic animals products give the gross weight and the net weight in kg of the whole consignment.</p>
Box I.18.	Temperature of products for transport and storage.
Box I.19.	For live aquatic animals <del>or gametes</del> give the total number of containers in which they are being transported. For aquatic animal products give the total number of packages.
Box I.20.	Identify the containers/seal numbers where required.
Box I.21.	Identify the type of packaging of aquatic animal products as defined in Recommendation No. 21 – Code of Passengers, Type of Cargo, Package and Packaging Materials of UN/CEFACT (United Nation Centre for Trade Facilitation and Electronic Business).
Box I.22.	<p>Intended use of the imported live aquatic animals or aquatic animal products.</p> <p>Breeding: applies to gametes and broodstock.</p> <p>Grow out: applies to live aquatic animals, <del>aquatic eggs and aquatic larvae</del> requiring time in culture.</p> <p>Slaughter: applies to live aquatic animals for slaughter.</p> <p>Restocking: applies to live aquatic animals for the purpose of rebuilding stocks.</p> <p>Ornamental: applies to live aquatic animals kept for companionship or enjoyment.</p> <p>Competition/Display: applies to live aquatic animals used for display or competition purposes.</p> <p>Human consumption: applies to live aquatic animals (without further aquaculture involved) or aquatic animals products intended for human consumption.</p>

Annex XVI (contd)

Box I.22.	Aquatic animal feed: means any product of animal origin (single or multiple), whether processed, semi-processed or raw, that is intended to be fed to aquatic animals.
	Further processing: applies to products of aquatic animal origin that have to be further processed before being suitable for end use. Other technical use: applies to aquatic animal products not intended for human or aquatic animal consumption. These include aquatic animal products that are intended for use in the pharmaceutical, medical, cosmetic and other industries. Such products may be subjected to extensive further processing. Technical use in live aquatic animals: applies to aquatic animal products used in live aquatic animals, e.g. to stimulate ovulation.
Box I.23.	Mark, if appropriate.
Box I.24.	Details on the nature of the commodity sufficient to identify it. For live aquatic animals <del>and gametes</del> : Category (i.e. amphibian, crustacean, fish or mollusc); Wild stocks or Cultured stocks; Species (scientific name); <del>Quantity or Weight</del> , and if required, Identification system; Batch number or other identification details; Age; Sex.
Box I.24.	For products of aquatic animal origin: Category (i.e. amphibian, crustacean, fish or mollusc); Wild stocks or Cultured stocks; Species (Scientific name); Approval number of establishment(s) (e.g. processing plant; cold store); Lot identification/date code; Number of packages.

3. Part II. Zoosanitary information

Box II.	Complete this part in accordance with the requirements agreed between the Competent Authorities of the importing and exporting countries in accordance with the recommendations in the <i>Aquatic Code</i> .
Box II.a.	Reference number: see box I.2.
Certifying Official	Name, address, official position, date of signature and official stamp of the Competent Authority.

## Annex XVI (contd)

## Article 5.10.2.

**Model Health Certificate for International Trade in Live Aquatic Animals and Gametes****COUNTRY :**

<b>Part I: Details of dispatched consignment</b>	I.1. Consignor: Name:		I.2. Certificate reference number:		
	Address:		I.3. Competent Authority:		
	I.4. Consignee: Name:  Address:				
	I.5. Country of origin:                      ISO code*		I.6. Zone or compartment of origin**:		
	I.7. Country of destination:                      ISO code*		I.8. Zone or compartment of destination**:		
	I.9. Place of origin: Name:  Address:				
	I.10. Place of shipment:		I.11. Date of departure:		
	I.12. Means of transport:  Aeroplane ?                      Ship ?                      Railway Road vehicle ?                      Other ?                      wagon ?		I.13. Expected border post:		
	Identification:		I.14. CITES permit No(s).**:		
	I.15. Description of commodity:		I.16. Commodity code (ISO code):		
			I.17. Total quantity/weight:		
	I.18.		I.19. Total number of containers:		
	I.20. Identification of container/seal number:		I.21. Type of packaging:		
	I.22. Commodities intended for use as:  Breeding ?                      Grow out ?                      Slaughter ?                      Restocking ? Ornamental ?                      Competition/Exhibition ?                      Other ? If other, specify.....				
	I.23. For import or admission: Definitive import ?                      Re-entry ?                      Temporary admission ?				
	I.24. Identification of commodities:  Amphibian?                      Crustacean ?                      Fish ?                      Mollusc ? Wild stock ?                      Cultured stock ?				
	Species (Scientific name)		Age *	Identification system*	
	Batch number*		Sex *		

\* Optional and \*\* If referenced in Part II.





## Annex XVI (contd)

## Article 5.10.3.

**Model Health Certificate for International Trade in Products of Aquatic Animal Origin****COUNTRY :**

<b>Part I: Details of dispatched consignment</b>	I.1. Consignor: Name:		I.2. Certificate reference number:		
	Address:		I.3. Competent Authority:		
	I.4. Consignee: Name:  Address:				
	I.5. Country of origin:		ISO code*	I.6. Zone or compartment of origin**:	
	I.7. Country of destination:		ISO code*	I.8. Zone or compartment of destination**:	
	I.9. Place of origin: Name:  Address:				
	I.10. Place of shipment:		I.11. Date of departure:		
	I.12. Means of transport:  Aeroplane ?      Ship ?      Railway wagon ? Road vehicle ?      Other ?		I.13. Expected border post:		
	Identification:		I.14. CITES permit No(s)**:		
	I.15. Description of commodity:		I.16. Commodity code (ISO code):		
			I.17. Total quantity/weight:		
	I.18. Temperature of product: Ambient ?    Chilled ?    Frozen ?		I.19. Total number of packages:		
	I.20. Identification of container/seal number:		I.21. Type of packaging:		
	I.22. Commodities intended for use as: Human consumption ? Further processing ? Other ? If other, specify.....		Aquatic animal feed ? Other technical use ? Technical use in live aquatic animals ? If Technical use, specify.....		
	I.23.				
	I.24. Identification of commodities:				
	Amphibian?		Crustacean ?		Fish ?
	Wild stock ?		Cultured stock ?		Mollusc ?
	Species (Scientific name)		Approval number of establishments		Lot ID/date code

\* Optional and \*\* If referenced in Part II.

**COUNTRY :**

<b>Part II. Zoosanitary information</b>	II.a. Certificate reference number	
	<p>II. The undersigned Certifying Official certifies that the product(s) of aquatic animal origin described above satisfy(ies) the following requirements:</p>	
	Certifying Official:	
	Name and address (in capital letters):	Official position:
	Date:	Signature:
	Stamp:	



## CHAPTER 7.2.

**TRANSPORT ~~WELFARE~~ OF FARMED FISH DURING  
TRANSPORT**

**Preamble:** Transport is stressful to fish. This Chapter provides information to minimise the effect of transport on the welfare of farmed fish (hereafter referred to as fish). It applies to their transport by air, by sea or on land within a country and between countries, and only considers the issues related to their welfare. Recommendations for measures to control the *aquatic animal health risks* related to the transport of fish are included in Chapter 5.4. on Recommendations for safe transport of *aquatic animals* and *aquatic animal products*.

## Article 7.2.1.

**Responsibilities**

All personnel handling fish throughout the transportation process are responsible for ensuring that consideration is given to the potential impact on the welfare of the fish.

The roles of each of the various personnel are defined below:

1. The responsibilities of the *Competent Authority* for the exporting and importing jurisdiction include:
  - a) establishing minimum standards for fish welfare during transport, including examination before, during and after their transport, appropriate certification and record keeping;
  - b) ensuring awareness and training of personnel involved in transport;
  - c) ensuring implementation of the standards, including possible accreditation of transport companies.
2. Owners and managers of fish at the start and at the end of the journey are responsible for:
  - a) the general health of the fish and their fitness for transport at the start of the journey and to ensure the overall welfare of the fish during the transport regardless of whether these duties are subcontracted to other parties;
  - b) ensuring competent personnel supervise operations at their facilities for fish to be loaded and unloaded in a manner that causes minimum stress and injury;
  - c) having a *contingency plan* available to enable humane killing of the fish at the start and at the end of the journey, as well as during the journey, if required;
  - d) ensuring the fish have a suitable environment to enter at their destination that ensures their welfare is maintained.
3. Transport companies, in cooperation with the farm owner/manager, are responsible for planning the transport to ensure that the transport can be carried out according to fish health and welfare standards including:

Annex XVII (contd)

- a) using a well maintained *vehicle* that is appropriate to the species to be transported;
  - b) ensuring that competent staff are available for loading and unloading; and to ensure swift, humane killing of the fish, if required;
  - c) having *contingency plans* to address emergencies and minimise stress during transport;
  - d) selecting suitable equipment for loading and unloading of the *vehicle*.
4. The person in charge of supervising the transport is responsible for all documentation relevant to the transport, and practical implementation of recommendations for welfare of fish during transport.

## Article 7.2.2.

**Competence**

All parties supervising transport activities, including loading and unloading, should have an appropriate knowledge and understanding to ensure that the welfare of the fish is maintained throughout the process. Competence may be gained through formal training and/or practical experience.

1. All persons handling live fish, or who are otherwise responsible for live fish during transport, should be competent according to their responsibilities listed in Article 7.2.1.
2. *Competent Authority*, farm owners/managers, and transport companies have a responsibility in providing training to their staff and personnel.
3. Any necessary training should address species-specific knowledge and may include practical experience on:
  - a) fish behaviour, physiology, general signs of *disease* and poor welfare;
  - b) operation and maintenance of equipment relevant to fish health and welfare;
  - c) water quality and suitable procedures for water exchange;
  - d) methods of live fish handling during transport, loading and unloading (species-specific aspects when relevant);
  - e) methods for inspection of the fish, management of situations frequently encountered during transport such as changes in water quality parameters, adverse weather conditions, and emergencies;
  - f) methods for the humane killing of fish in accordance with Chapter X.X. on the Humane killing of fish for disease control purposes (in preparation);
  - g) logbooks and record keeping.

## Article 7.2.3.

**Planning the transport**1. General considerations

Adequate planning is a key factor affecting the welfare of fish during transportation. The pre-transport preparation, the duration and route of a transport should be determined by the purpose of the transport e.g. biosecurity issues, transport of fish for stocking farms or resource enhancement, for slaughter/killing for disease control purposes. Before the transport starts, plans should be made in relation to:

- a) type of *vehicle* and transport equipment required;
- b) route – such as distance, expected weather and/or sea conditions;
- c) nature and duration of the transport;
- d) need for care of the fish during the transport;
- e) emergency response procedures related to fish welfare;
- f) assessment of the necessary biosecurity level (e.g. washing and *disinfection* practices, safe places for changing water, treatment of transport water (refer to Chapter 5.4)).

2. Vehicle design and maintenance

- a) *Vehicles* and *containers* used for transport of fish should be appropriate to the species, size, weight and number of fish to be transported.
- b) *Vehicles* and *containers* should be maintained in good mechanical and structural condition to prevent predictable and avoidable damage of the *vehicle* that may directly or indirectly affect the welfare of transported fish.
- c) *Vehicles* (if relevant) and *containers* should have adequate circulation of water and equipment for oxygenation as required to meet variations in the conditions during the journey and the needs of the animals being transported, including the closing of valves in well boats for biosecurity reasons.
- d) The fish should be accessible to inspection en route, if necessary, to ensure that fish welfare standards can be assessed.
- e) Documentation that focuses on fish welfare and thus carried with the *vehicle* should include a transport logbook of stocks received, contact information, mortalities and disposal/storage logs.

3. Water

- a) Water quality (e.g. oxygen, CO<sub>2</sub> and NH<sub>3</sub> level, pH, temperature, salinity) should be appropriate for the species being transported and method of transportation.
- b) Equipment to monitor and maintain water quality may be required depending on the length of the transport.

Annex XVII (contd)4. Preparation of fish for the transport

- a) Prior to transport, feed should be withheld from the fish, taking into consideration the fish species and life stage to be transported.
- b) The ability of the fish to cope with the stress of transport should be assessed based on health status, previous handling and recent transport history of the fish. Generally, only fish that are fit for transport should be loaded. ~~Except for Transport for disease control purposes, should be in accordance with Chapter X.X. on the humane killing of fish for disease control purposes (in preparation): (under study)~~ Only fish that are fit for transport should be loaded.
- c) Reasons for considering of unfitness of fish for transport includes:
  - i) displaying clinical signs of *disease*;
  - ii) significant physical injuries or abnormal behaviour, such as rapid ventilation or abnormal swimming;
  - iii) recent exposure to stressors that adversely affect behaviour or physiological state (for example extreme temperatures, chemical agents).

5. Species-specific recommendations

Transport procedures should take account of variations in the behaviour and specific needs of the transported fish species. Handling procedures that are successful with one species may be ineffective or dangerous for another species.

Some species or life stages may need to be physiologically prepared prior to entering a new environment, such as by feed deprivation or osmotic acclimatisation.

6. Contingency plans

There should be a *contingency plan* that identifies the important adverse fish welfare events that may be encountered during the transport, the procedures for managing each event and the action to be taken in such an event. For each event, the plan should document the actions to be undertaken and the responsibilities of all parties involved, including communications and record keeping.

Article 7.2.4.

**Documentation**

1. Fish should not be loaded until the required documentation is complete.
2. The documentation accompanying the consignment (the transport log) should include:
  - a) description of the consignment (e.g. date, time, and place of loading, species, biomass load);
  - b) description of the transport plan (e.g. including route, water exchanges, expected time, date and place of arrival and unloading and receiver contact information).
3. The transport log should be made available to the dispatcher and the receiver of the consignment as well as to the *Competent Authority* upon request. Transport logs from previous journeys should be kept after completion of the transport for a period of time as specified by the *Competent Authority*.



## Article 7.2.5.

**Loading the fish**

1. The issues which should be addressed to avoid unnecessary stress and injury to the fish include:
  - a) crowding procedure in farm pond, tank, net or cage prior to loading;
  - b) equipment (such as nets, pumps, pipes and fittings) both improperly constructed, for example with sharp bends or protrusions or improperly operated by overloading the system with fish of incorrect size or number of fish per time unit according to the equipments capacity;
  - c) water quality - some species of fish should be acclimatised if there is a likelihood of the fish being transported in water of a significantly different temperature or other water parameters.
2. The density of fish in a vehicle and/or container should be in accordance with scientific data where available and not exceed what is generally accepted for a given species and a given situation.
3. Loading should be carried out, or supervised, by operators with knowledge and experience of the behaviour and other characteristics of the fish species being loaded to ensure that the welfare of the fish is maintained.

## Article 7.2.6.

**Transporting the fish**

1. General considerations
  - a) Periodic inspections should take place during the transport to verify that acceptable welfare is being maintained.
  - b) Ensure that water quality is monitored and the necessary adjustments made to avoid extreme conditions.
  - c) Travel in a manner that minimises uncontrolled movements of the fish.
2. Sick or injured fish
  - a) In the event of a fish health emergency during transport, the *vehicle* operator should initiate the procedure to implement the *contingency plan* (see point 6 of Article 7.2.3.).
  - b) If the killing of fish is necessary during the transport, the person in charge should ensure that the killing is carried out humanely in accordance with Chapter XX. on the Humane killing of fish for disease control purposes (in preparation), and in compliance with relevant legislation.

## Article 7.2.7.

**Unloading the fish**

1. The principles of good fish handling during loading apply equally during unloading.

Annex XVII (contd)

2. Fish should be unloaded as soon as possible after arrival at the destination, allowing sufficient time to ensure that the unloading procedure does not cause harm to the fish. Some species of fish should be acclimatised if there is a likelihood of the fish being unloaded into water of a significantly different quality (such as temperature, salinity, pH).
3. Moribund or seriously injured fish should be removed and humanely killed in accordance with Chapter X.X. on the Humane killing of fish for disease control purposes (in preparation).

Article 7.2.8.

**Post-transport activities**

1. The person in charge of receiving the fish should closely observe them during the post-transport period, and keep appropriate records.
2. Fish showing abnormal clinical signs should be humanely killed in accordance with Chapter X.X. on the Humane killing of fish for disease control purposes (in preparation) or isolated and examined by a *veterinarian* or other qualified personnel, who may recommend treatment.
3. Significant problems associated with transport should be evaluated to prevent recurrence of such problems.

---

-----  
- text deleted

REVISED ARTICLE X.X.8.  
 AN EXAMPLE (DISEASE X)  
 TO BE APPLIED ACROSS ALL DISEASE CHAPTERS  
 (SECTIONS 8, 9, 10 AND 11)

[...]

Article X.X.8.

**Importation of live aquatic animals for aquaculture from a country, zone or compartment not declared free from 'Disease X'**

[...]

2. If the intention of the introduction is the establishment of a new stock, the Code of Practice on the Introductions and Transfers of Marine Organisms of the International Council for the Exploration of the Seas (ICES) should be considered ~~followed~~.
3. For the purposes of the *Aquatic Code*, relevant aspects of the ICES Code (full version see: <http://www.ices.dk/indexfla.asp>) may be summarised to the following ~~main~~ points:
  - a) identify stock of interest (cultured or wild) in its current location;
  - b) evaluate stock health/disease history;
  - c) take and test samples for abalone herpes-like virus, pests and general health/disease status;
  - d) import and quarantine in a secure facility a founder (F-0) population;
  - e) produce F-1 generation from the F-0 stock in *quarantine*;
  - f) culture F-1 stock and at critical times in its development (life cycle) sample and test for abalone herpes-like virus and perform general examinations for pests and general health/disease status;
  - g) if 'Disease X' is not detected, pests are not present, and the general health/disease status of the stock is considered to meet the *basic biosecurity conditions* of the *importing country, zone or compartment*, the F-1 stock may be defined as free of infection with 'Disease X' or specific pathogen free (SPF) for 'Disease X';
  - h) release SPF F-1 stock from *quarantine* for *aquaculture* or stocking purposes in the country, *zone or compartment*.
4. With respect to point 3e), quarantine conditions should be conducive to multiplication of the pathogen and eventually to clinical expression. If quarantine conditions are not suitable for pathogen multiplication and development, the recommended diagnostic approach might not be sensitive enough to detect low infection level.

Annex XVIII (contd)

This Article does not apply to *commodities* referred to in point 1 of Article X.X.3.

-----

– text deleted

CHAPTER ~~112.2.~~ X.

## INFECTION WITH ABALONE HERPES-LIKE VIRUS

Article ~~112.2.~~X.1.

For the purposes of the *Aquatic Code*, infection with abalone herpes-like virus means ~~herpes-like virus associated manifestation in abalone~~; any form of the abalone viral mortality complex (AVM) caused by abalone herpes-like virus.

~~Methods for conducting surveillance, diagnosis and confirmatory identification of infection with abalone herpes-like virus~~ Information on methods for diagnosis are provided in the *Aquatic Manual* (under development).

Article ~~112.2.~~X.2.**Scope**

The recommendations in this Chapter apply to: *Haliotis diversicolor* (subspecies *aquaticilis* and *supertexta*) and in *Haliotis laevegata*, *H. rubra* and hybrids of *H. laevegata* x *H. rubra*. These recommendations also apply to any other *susceptible species* referred to in the *Aquatic Manual* when traded internationally.

Article ~~112.2.~~X.3.**Commodities**

1. When authorising the importation or transit of the following *commodities*, the *Competent Authorities* should not require any abalone herpes-like virus related conditions, regardless of the abalone herpes-like virus status of the *exporting country, zone* or *compartment*:
  - a) For the species referred to in Article ~~112.2.~~X.2. intended for any purpose:
    - i) *commodities* treated in a manner that inactivates the *disease agent* e.g. canned or pasteurized products;
    - ~~ii) biological samples preserved for diagnostic applications in such a manner as to inactivate the disease agent.~~
  - b) [The following *commodities* destined for human consumption from the species referred to in Article ~~112.2.~~X.2. which have been prepared and packaged for direct retail trade:
    - i) off the shell (chilled or frozen).

For the *commodities* referred to ~~listed~~ in point 1b), OIE Members may wish to consider introducing internal measures to address the risks associated with ~~prevent~~ the *commodity* being used for any purpose other than for human consumption. (under study)

2. When authorising the importation or transit of *commodities* of a species referred to in Article ~~112.2.~~X.2., other than *commodities* referred to in point 1 of Article ~~112.2.~~X.3., the *Competent Authorities* should require the conditions prescribed in Articles ~~112.2.~~X.7. to ~~112.2.~~X.11. relevant to the abalone herpes-like virus status of the *exporting country, zone* or *compartment*.

Annex XIX (contd)

3. When considering the importation/transit from an *exporting country, zone or compartment* not declared free of infection with abalone herpes-like virus of a *commodity* from **mollusc** species not covered in Article 112.2.X.2. **or in point 1b) of Article 112.2.X.3.** but which could reasonably be expected to be a potential mechanical vector for abalone herpes-like virus, the *Competent Authorities* should conduct a *risk analysis* in accordance with the recommendations in the *Aquatic Code*. The *exporting country* should be informed of the outcome of this assessment.

Article 112.2.X.4.

**Abalone herpes-like virus free country**

A country may make a *self-declaration of freedom* from abalone herpes-like virus if it meets the conditions in points 1, 2, 3 or 4 below.

If a country shares a *zone* with one or more other countries, it can only make a *self-declaration of freedom* from abalone herpes-like virus if all the areas covered by the shared water are declared abalone herpes-like virus free *zones* (see Article 112.2.X.5.).

1. A country where none of the *susceptible species* referred to in Article 112.2.X.2. is present may make a *self-declaration of freedom* from abalone herpes-like virus when *basic biosecurity conditions* have been continuously met in the country for at least the past 2 years.

OR

2. A country where any *susceptible species* referred to in Article 112.2.X.2. are present but there has been no observed occurrence of the *disease* for at least the past 10 years despite conditions – in all areas where the species are present – that are conducive to its clinical expression, as described in the corresponding Chapter 2.2.9. of the *Aquatic Manual*, may make a *self-declaration of freedom* from abalone herpes-like virus when *basic biosecurity conditions* have been continuously met in the country for at least the past 2 years and infection with abalone herpes-like virus is not known to be established in wild populations.

OR

3. A country where the last known clinical occurrence was within the past 10 years or where the *infection* status prior to *targeted surveillance* was unknown (e.g. because of the absence of conditions conducive to clinical expression as described in the corresponding Chapter 2.2.9. of the *Aquatic Manual*) may make a *self-declaration of freedom* from abalone herpes-like virus when:
  - a) *basic biosecurity conditions* have been continuously met for at least the past 2 years; and
  - b) *targeted surveillance*, as described in Chapters 1.4.3.3.1. of the *Aquatic Code* and 2.2.9. of the *Aquatic Manual*, has been in place for at least the past 2 years without detection of abalone herpes-like virus.

OR

4. A country that has previously made a *self-declaration of freedom* from abalone herpes-like virus but in which the *disease* is subsequently detected may make a *self-declaration of freedom* from abalone herpes-like virus again when the following conditions have been met:
  - a) on detection of the *disease*, the affected area was declared an *infected zone* and a ~~buffer~~ protection zone was established; and

- b) infected populations have been destroyed or removed from the *infected zone* by means that minimise the *risk* of further spread of the *disease*, and the appropriate *disinfection* procedures (see *Aquatic Manual*) have been completed; and
- c) *targeted surveillance*, as described in Chapters ~~1.4.3.3.1~~ of the *Aquatic Code* and ~~2.2.9~~ of the ~~*Aquatic Manual*~~, has been in place for at least the past 2 years without detection of abalone herpes-like virus; and
- d) previously existing *basic biosecurity conditions* have been reviewed and modified as necessary and have continuously been in place for at least the past 2 years.

In the meantime, part of the non-affected area may be declared a free *zone* provided that such part meets the conditions in point 3 of Article ~~112.2.X.5~~.

Article ~~112.2.X.5~~.

### **Abalone herpes-like virus free zone or free compartment**

A *zone* or *compartment* free from abalone herpes-like virus may be established within the *territory* of one or more countries of infected or unknown status for infection with abalone herpes-like virus and declared free by the *Competent Authority(ies)* of the country(ies) concerned if the *zone* or *compartment* meets the conditions referred to in points 1, 2, 3 or 4 below.

If a *zone* or *compartment* extends over more than one country, it can only be declared a abalone herpes-like virus free *zone* or *compartment* if the conditions outlined below apply to all areas of the *zone* or *compartment*.

1. In a country of unknown status for abalone herpes-like virus, a *zone* or *compartment* where none of the *susceptible species* referred to in Article ~~112.2.X.2~~ is present may be declared free from abalone herpes-like virus when *basic biosecurity conditions* have been continuously met in the *zone* or *compartment* for at least the past 2 years.

OR

2. In a country of unknown status for abalone herpes-like virus, a *zone* or *compartment* where any *susceptible species* referred to in Article ~~112.2.X.2~~ are present but there has been no observed occurrence of the *disease* for at least the past 10 years despite conditions – in all areas where the species are present – that are conducive to its clinical expression, as described in the corresponding ~~Chapter 2.2.9~~ of the *Aquatic Manual*, may be declared free from abalone herpes-like virus when *basic biosecurity conditions* have been continuously met in the *zone* or *compartment* for at least the past 2 years and infection with abalone herpes-like virus is not known to be established in wild populations.

OR

3. A *zone* or *compartment* where the last known clinical occurrence was within the past 10 years or where the *infection* status prior to *targeted surveillance* was unknown (e.g. because of the absence of conditions conducive to clinical expression as described in the corresponding ~~Chapter 2.2.9~~ of the *Aquatic Manual*) may be declared free from abalone herpes-like virus when:
  - a) *basic biosecurity conditions* have been continuously met for at least the past 2 years; and
  - b) *targeted surveillance*, in Chapters ~~1.4.3.3.1~~ of the *Aquatic Code* and ~~2.2.9~~ of the ~~*Aquatic Manual*~~, has been in place for at least the past 2 years without detection of abalone herpes-like virus.

Annex XIX (contd)

OR

4. A *zone* previously declared free from abalone herpes-like virus but in which the *disease* is detected may again be declared free from ~~*M. mackini*~~ abalone herpes-like virus ~~again~~ when the following conditions have been met:
- a) on detection of the *disease*, the affected area was declared an *infected zone* and a ~~buffer~~ protection zone was established; and
  - b) infected populations have been destroyed or removed from the *infected zone* by means that minimise the *risk* of further spread of the *disease*, and the appropriate *disinfection* procedures (see *Aquatic Manual*) have been completed; and
  - c) *targeted surveillance*, as described in Chapters ~~1.4.3.3.1.~~ of the *Aquatic Code* and ~~2.2.9.~~ of the ~~*Aquatic Manual*~~, has been in place for at least the past 2 years without detection of abalone herpes-like virus; and
  - d) previously existing *basic biosecurity conditions* have been reviewed and modified as necessary and have continuously been in place for at least the past 2 years.

Article ~~112.2.~~X.6.**Maintenance of free status**

A country, *zone* or *compartment* that is declared free from abalone herpes-like virus following the provisions of points 1 or 2 of Articles ~~112.2.~~X.4. or ~~112.2.~~X.5. (as relevant) may maintain its status as abalone herpes-like virus free provided that *basic biosecurity conditions* are continuously maintained.

A country, *zone* or *compartment* that is declared free from abalone herpes-like virus following the provisions of point 3 of Articles ~~112.2.~~X.4. or ~~112.2.~~X.5. (as relevant) may discontinue *targeted surveillance* and maintain its status as abalone herpes-like virus free provided that conditions that are conducive to clinical expression of infection with abalone herpes-like virus, as described in ~~Chapter 2.2.9.~~ in the corresponding chapter of the *Aquatic Manual*, exist and *basic biosecurity conditions* are continuously maintained.

However, for declared free *zones* or *compartments* in infected countries and in all cases where conditions are not conducive to clinical expression of infection with abalone herpes-like virus, *targeted surveillance* needs to be continued at a level determined by the *Competent Authority* on the basis of the likelihood of *infection*.

Article ~~112.2.~~X.7.**Importation of live aquatic animals from a country, zone or compartment declared free from abalone herpes-like virus**

When importing live *aquatic animals* of species referred to in Article ~~112.2.~~X.2. from a country, *zone* or *compartment* declared free from abalone herpes-like virus, the *Competent Authority* of the *importing country* should require an *international aquatic animal health certificate* issued by the *Competent Authority* of the *exporting country* or a *certifying official* approved by the *importing country*.

This *certificate* must certify, on the basis of the procedures described in Articles ~~112.2.~~X.4. or ~~112.2.~~X.5. (as applicable), whether the place of production of the *aquatic animal* is a country, *zone* or *compartment* declared free from abalone herpes-like virus.

The *certificate* should be in accordance with the Model Certificate in ~~Chapter 5.10.~~ Appendix 4.1.2.



This Article does not apply to *commodities* referred to in point 1 of Article ~~112.2.X.3~~.

Article ~~112.2.X.8~~.

**Importation of live aquatic animals for aquaculture from a country, zone or compartment not declared free from abalone herpes-like virus**

1. When importing, for *aquaculture* live *aquatic animals* of species referred to in Article ~~112.2.X.2~~ from a country, zone or compartment not declared free from abalone herpes-like virus, the *Competent Authority* of the *importing country* should assess the *risk* and, if justified, apply the following *risk* mitigation measures:
  - a) the direct delivery to and lifelong holding of the consignment in biosecure facilities for continuous isolation from the local environment; and
  - b) the treatment of all effluent and waste material in a manner that ensures inactivation of abalone herpes-like virus.
2. If the intention of the introduction is the establishment of a new stock, the Code of Practice on the Introductions and Transfers of Marine Organisms of the International Council for the Exploration of the Seas (ICES) should be considered followed.
3. For the purposes of the *Aquatic Code*, relevant aspects of the ICES Code (full version see: <http://www.ices.dk/indexfla.asp>) may be summarised to the following ~~main~~ points:
  - a) identify stock of interest (cultured or wild) in its current location;
  - b) evaluate stock health/disease history;
  - c) take and test samples for abalone herpes-like virus, pests and general health/disease status;
  - d) import and quarantine in a secure facility a founder (F-0) population;
  - e) produce F-1 generation from the F-0 stock in *quarantine*;
  - f) culture F-1 stock and at critical times in its development (life cycle) sample and test for abalone herpes-like virus and perform general examinations for pests and general health/disease status;
  - g) if abalone herpes-like virus is not detected, pests are not present, and the general health/disease status of the stock is considered to meet the *basic biosecurity conditions* of the *importing country, zone or compartment*, the F-1 stock may be defined as free of infection with abalone herpes-like virus ~~*M. mackini*~~ or specific pathogen free (SPF) for abalone herpes-like virus;
  - h) release SPF F-1 stock from *quarantine* for *aquaculture* or stocking purposes in the country, zone or compartment.
4. With respect to point 3e), quarantine conditions should be conducive to multiplication of the pathogen and eventually to clinical expression. If quarantine conditions are not suitable for pathogen multiplication and development, the recommended diagnostic approach might not be sensitive enough to detect low infection level.

This Article does not apply to *commodities* referred to in point 1 of Article ~~112.2.X.3~~.

Annex XIX (contd)Article ~~112.2~~.X.9.**Importation of live aquatic animals for processing for human consumption from a country, zone or compartment not declared free from abalone herpes-like virus**

When importing, for processing for human consumption, live *aquatic animals* of species referred to in Article ~~112.2~~.X.2. from a country, *zone* or *compartment* not declared free from abalone herpes-like virus, the *Competent Authority* of the *importing country* should assess the *risk* and, if justified, require that:

1. the consignment be delivered directly to and held in *quarantine* facilities until processing and/or consumption; and
2. all effluent and waste material from the processing be treated in a manner that ensures inactivation of abalone herpes-like virus.

This Article does not apply to *commodities* referred to in point 1 of Article ~~112.2~~.X.3.

Article ~~112.2~~.X.10.**Importation of aquatic animal products from a country, zone or compartment declared free from abalone herpes-like virus**

When importing *aquatic animal products* of species referred to in Article ~~112.2~~.X.2. from a country, *zone* or *compartment* declared free from abalone herpes-like virus, the *Competent Authority* of the *importing country* should require that the consignment be accompanied by an *international aquatic animal health certificate* issued by the *Competent Authority* of the *exporting country* or a *certifying official* approved by the *importing country*.

This *certificate* must certify, on the basis of the procedures described in Articles ~~112.2~~.X.4. or ~~112.2~~.X.5. (as applicable), whether or not the place of production of the consignment is a country, *zone* or *compartment* declared free from abalone herpes-like virus.

The *certificate* should be in accordance with the Model Certificate in Chapter 5.10, Appendix X.X.X. (under study).

This Article does not apply to *commodities* referred to in point 1 of Article ~~112.2~~.X.3.

Article ~~112.2~~.X.11.**Importation of aquatic animal products from a country, zone or compartment not declared free from abalone herpes-like virus**

When importing *aquatic animal products* of species referred to in Article ~~112.2~~.X.2. from a country, *zone* or *compartment* not declared free from abalone herpes-like virus, the *Competent Authority* of the *importing country* should assess the *risk* and apply appropriate *risk* mitigation measures.

This Article does not apply to *commodities* referred to in point 1 of Article ~~112.2~~.X.3.

---

-----  
- text deleted

## CHAPTER 9.X.

**NECROTISING HEPATOPANCREATITIS**

## Article 9.X.1.

For the purposes of the *Aquatic Code*, necrotising hepatopancreatitis (NHP) means *infection* with necrotising hepatopancreatitis bacteria (NHP-B). This obligate intracellular bacterium is a member of the order *α-Proteobacteria*.

Information on methods for *diagnosis* are provided in the *Aquatic Manual* (under development).

## Article 9.X.2.

**Scope**

The recommendations in this Chapter apply to: Pacific white shrimp (*Penaeus vannamei*), blue shrimp (*P. stylirostris*), northern white shrimp (*P. setiferus*) and northern brown shrimp (*P. aztecus*). These recommendations also apply to any other *susceptible species* referred to in the *Aquatic Manual* when traded internationally.

For the purposes of this Chapter, the terms shrimp and prawn are used interchangeably.

## Article 9.X.3.

**Commodities**

1. When authorising the importation or transit of the following *commodities*, the *Competent Authorities* should not require any NHP related conditions, regardless of the NHP status of the *exporting country, zone or compartment*.
  - a) For the species referred to in Article 9.X.2. intended for any purpose:
    - [i) cooked products;
    - ii) canned products;
    - iii) crustacean oil;
    - iv) crustacean *meal*; and
    - v) chemically extracted chitin.] under study
  - b) [The following products destined for human consumption from species referred to in Article 9.X.2. which have been prepared and packaged for direct retail trade:

For the *commodities* listed in point 1b), OIE Members may wish to consider introducing internal measures to address the *risks* associated with the *commodity* being used for any purpose other than for human consumption] under study.

Annex XX (contd)

2. When authorising the importation or transit of the *commodities* of a species referred to in Article 9.X.2., other than those listed in point 1 of Article 9.X.3., the *Competent Authorities* should require the conditions prescribed in Articles 9.X.7. to 9.X.11. relevant to the NHP status of the *exporting country, zone or compartment*.
3. When considering the importation/ transit from an *exporting country, zone or compartment* not declared free of NHP of a *commodity* of a species not covered in Article 9.X.2. but which could reasonably be expected to be a potential mechanical vector for NHP-B, the *Competent Authorities* should conduct a *risk analysis* in accordance with the recommendations in the *Aquatic Code*. The *exporting country* should be informed of the outcome of this assessment.

Article 9.X.4.

**Necrotising hepatopancreatitis free country**

A country may make a *self-declaration of freedom* from NHP if it meets the conditions in points 1, 2, 3 or 4 below.

If a country shares a *zone* with one or more other countries, it can only make a *self-declaration of freedom* from NHP if all the areas covered by the shared water are declared NHP free countries or *zones* (see Article 9.X.5.).

1. A country where none of the *susceptible species* referred to in Article 9.X.2. is present may make a *self-declaration of freedom* from NHP when *basic biosecurity conditions* have been met continuously in the country for at least the past 2 years.

OR

2. A country where the *susceptible species* referred to in Article 9.X.2. are present but there has been no observed occurrence of the *disease* for at least the past 10 years despite conditions that are conducive to its clinical expression, as described in the corresponding chapter of the *Aquatic Manual*, may make a *self-declaration of freedom* from NHP when *basic biosecurity conditions* have been continuously met in the country for at least the past 2 years.

OR

3. A country where the last observed occurrence of the *disease* was within the past 10 years or where the *infection* status prior to *targeted surveillance* was unknown (e.g. because of the absence of conditions conducive to its clinical expression as described in the corresponding chapter of the *Aquatic Manual*), may make a *self-declaration of freedom* from NHP when:
  - a) *basic biosecurity conditions* have been met continuously for at least the past 2 years; and
  - b) *targeted surveillance*, as described in Chapters 1.4. of the *Aquatic Code*, has been in place for at least the last 2 years without detection of NHP-B.

OR

4. A country that has previously made a *self-declaration of freedom* from NHP but in which the *disease* is subsequently detected may make a *self-declaration of freedom* from NHP again when the following conditions have been met:
  - a) on detection of the *disease*, the affected area was declared an *infected zone* and a *protection zone* was established; and

- b) infected populations have been destroyed or removed from the *infected zone* by means that minimise the risk of further spread of the *disease*, and the appropriate *disinfection* procedures (see *Aquatic Manual*) have been completed; and
- c) *targeted surveillance*, as described in Chapter 1.4. of the *Aquatic Code*, has been in place for at least the past 2 years without detection of NHP-B and;
- d) previously existing *basic biosecurity conditions* have been reviewed and modified as necessary and have continuously been in place for at least the past 2 years.

In the meantime, part of the non-affected area may be declared a free *zone* provided that such part meets the conditions in point 3 of Article 9.X.5.

Article 9.X.5.

### **Necrotising hepatopancreatitis free zone or free compartment**

A *zone* or *compartment* within the *territory* of one or more countries not declared free from NHP may be declared free by the *Competent Authority(ies)* of the country(ies) concerned if the *zone* or *compartment* meets the conditions referred to in points 1, 2, 3 or 4 below.

If a *zone* or *compartment* extends over more than one country, it can only be declared a NHP free *zone* or *compartment* if all the relevant *Competent Authority(ies)* confirm that the conditions have been met.

1. A *zone* or *compartment* where none of the *susceptible species* referred to in Article 9.X.2. is present may be declared free from NHP when *basic biosecurity conditions* have been met continuously in the *zone* or *compartment* for at least the past 2 years.

OR

2. A *zone* or *compartment* where the *susceptible species* referred to in Article 9.X.2. are present but in which there has not been any observed occurrence of the *disease* for at least the past 10 years despite conditions that are conducive to its clinical expression, as described in the corresponding chapter of the *Aquatic Manual*, may be declared free from NHP when *basic biosecurity conditions* have been continuously met in the *zone* or *compartment* for at least the past 2 years.

OR

3. A *zone* or *compartment* where the last observed occurrence of the *disease* was within the past 10 years or where the *infection* status prior to *targeted surveillance* was unknown (e.g. because of the absence of conditions conducive to clinical expression, as described in the corresponding chapter of the *Aquatic Manual*), may be declared free from NHP when:
  - a) *basic biosecurity conditions* have been met continuously for at least the past 2 years; and
  - b) *targeted surveillance*, as described in Chapter 1.4. of the *Aquatic Code*, has been in place, through the *zone* or *compartment*, for at least the past 2 years without detection of NHP-B.

OR

4. A *zone* previously declared free from NHP but in which the *disease* is detected may be again declared free from NHP when the following conditions have been met:

Annex XX (contd)

- a) on detection of the *disease*, the affected area was declared an *infected zone* and a *protection zone* was established; and
- b) infected populations have been destroyed or removed from the *infected zone* by means that minimise the *risk* of further spread of the *disease*, and the appropriate *disinfection* procedures (see *Aquatic Manual*) have been completed; and
- c) *targeted surveillance*, as described in Chapter 1.4. of the *Aquatic Code*, has been in place for at least the past 2 years without detection of NHP-B and;
- d) previously existing *basic biosecurity conditions* have been reviewed and modified as necessary and have continuously been in place for at least the past 2 years.

Article 9.X.6.

**Maintenance of free status**

A country, *zone* or *compartment* that is declared free from NHP following the provisions of points 1 or 2 of Articles 9.X.4. or 9.X.5. (as relevant) may maintain its status as NHP free provided that *basic biosecurity conditions* are continuously maintained.

A country, *zone* or *compartment* that is declared free from NHP following the provisions of point 3 of Articles 9.X.4. or 9.X.5. (as relevant) may discontinue *targeted surveillance* and maintain its status as NHP free provided that conditions that are conducive to clinical expression of NHP, as described in the corresponding chapter of the *Aquatic Manual*, exist, and *basic biosecurity conditions* are continuously maintained.

However, for declared free *zones* or *compartments* in infected countries and in all cases where conditions are not conducive to clinical expression of NHP, *targeted surveillance* needs to be continued at a level determined by the *Competent Authority* on the basis of the likelihood of *infection*.

Article 9.X.7.

**Importation of live aquatic animals from a country, zone or compartment declared free from necrotising hepatopancreatitis**

When importing live *aquatic animals* of the species referred to in Article 9.X.2. from a country, *zone* or *compartment* declared free from NHP, the *Competent Authority* of the *importing country* should require an *international aquatic animal health certificate* issued by the *Competent Authority* of the *exporting country* or a *certifying official* approved by the *importing country* attesting that, on the basis of the procedures described in Articles 9.X.4. or 9.X.5. (as applicable), the place of production of the *aquatic animal* is a country, *zone* or *compartment* declared free from NHP.

The *certificate* should be in accordance with the Model Certificate in Chapter 5.10.

This Article does not apply to *commodities* listed in point 1 of Article 9.X.3.

Article 9.X.8.

**Importation of live aquatic animals for aquaculture from a country, zone or compartment not declared free from necrotising hepatopancreatitis**

1. When importing, for *aquaculture*, live *aquatic animals* of species referred to in Article 9.X.2. from a country, *zone* or *compartment* not declared free from NHP, the *Competent Authority* of the *importing country* should assess the *risk* and, if justified, apply the following *risk* mitigation measures:
  - a) the direct delivery to and lifelong holding of the consignment in biosecure facilities for continuous isolation from the local environment; and
  - b) the treatment of all effluent and waste materials in a manner that ensures inactivation of NHP-B.
  
2. If the intention of the introduction is the establishment of a new stock, the Code of Practice on the Introductions and Transfers of Marine Organisms of the International Council for the Exploration of the Seas (ICES) should be considered.
  
3. For the purposes of the *Aquatic Code*, relevant aspects of the ICES Code (full version see: <http://www.ices.dk/indexfla.asp>) may be summarised to the following points:
  - a) identify stock of interest (cultured or wild) in its current location;
  - b) evaluate stock health/ *disease* history;
  - c) take and test samples for NHP-B, pests and general health/ *disease* status;
  - d) import and quarantine in a secure facility a founder (F-0) population;
  - e) produce F-1 generation from the F-0 stock in *quarantine*;
  - f) culture F-1 stock and at critical times in its development (life cycle) sample and test for NHP-B and perform general examinations for pests and general health/ *disease* status;
  - g) if NHP-B is not detected, pests are not present, and the general health/ *disease* status of the stock is considered to meet *basic biosecurity conditions* of the *importing country*, *zone*, or *compartment*, the F-1 stock may be defined as NHP free or specific pathogen free (SPF) for NHP-B;
  - h) release SPF F-1 stock from *quarantine* for *aquaculture* or stocking purposes in the country, *zone* or *compartment*.
  
4. With respect to point 3e), quarantine conditions should be conducive to multiplication of the pathogen and eventually to clinical expression. If quarantine conditions are not suitable for pathogen multiplication and development, the recommended diagnostic approach might not be sensitive enough to detect low infection level.

This Article does not apply to *commodities* listed in point 1 of Article 9.X.3.

#### Article 9.X.9.

### **Importation of live aquatic animals for human consumption from a country, zone or compartment not declared free from necrotising hepatopancreatitis**

When importing, for human consumption, live *aquatic animals* of the species referred to in Article 9.X.2. from a country, *zone* or *compartment* not declared free from NHP, the *Competent Authority* of the *importing country* should assess the *risk* and, if justified, require that:

Annex XX (contd)

1. the consignment be delivered directly to and held in isolation until *processing* and/or consumption; and
2. all effluent, dead *aquatic animals* and waste materials from the *processing* be treated in a manner that ensures inactivation of NHP-B.

Members may wish to consider introducing internal measures to prevent such *commodities* being used for any purpose other than for human consumption.

This Article does not apply to *commodities* listed in point 1 of Article 9.X.3.

Article 9.X.10.

**Importation of aquatic animal products from a country, zone or compartment declared free from necrotising hepatopancreatitis**

When importing *aquatic animal products* of the species referred to in Article 9.X.2. from a country, *zone* or *compartment* declared free from NHP, the *Competent Authority* of the *importing country* should require an *international aquatic animal health certificate* issued by the *Competent Authority* of the *exporting country* or a *certifying official* approved by the *importing country* attesting that, on the basis of the procedures described in Articles 9.X.4. or 9.X.5. (as applicable), the place of production of the consignment is a country, *zone* or *compartment* declared free from NHP.

The *certificate* should be in accordance with the Model Certificate in Chapter 5.10.

This Article does not apply to *commodities* listed in point 1 of Article 9.X.3.

Article 9.X.11.

**Importation of aquatic animal products from a country, zone or compartment not declared free from necrotising hepatopancreatitis**

When importing *aquatic animal products* of the species referred to in Article 9.X.2. from a country, *zone* or *compartment* not declared free from NHP, the *Competent Authority* of the *importing country* should assess the risk and apply appropriate risk mitigation measures.

This Article does not apply to *commodities* listed in point 1 of Article 9.X.3.



## DISINFECTED EGGS – NEW ARTICLES

### Article 10.4.X.

#### **Importation of disinfected eggs for aquaculture from a country, zone or compartment not declared free from infectious haematopoietic necrosis**

1. When importing disinfected eggs of the species referred to in Article 10.4.2 for aquaculture from a country, zone or compartment not declared free from IHN, the Competent Authority of the importing country should conduct a risk assessment based on information provided by the Competent Authority of the exporting country, including at least:
  - a) the IHN virus status of the water to be used during the disinfection of the eggs
  - b) the level of infection with IHN virus in broodstock (ovarian fluid and milt); and
  - c) the temperature and pH of the water to be used for disinfection.
2. If the Competent Authority of the importing country concludes that the importation is acceptable, it should apply the following risk mitigation measures including:
  - a) the eggs should be disinfected prior to importing, according to the methods described in Chapter 1.1.3. of the Aquatic Manual or those specified by the Competent Authority of the importing country; and
  - b) between disinfection and the import, eggs must be kept in specific pathogen free water.
3. When importing disinfected eggs of the species referred to in Article 10.4.2. for aquaculture from a country, zone or compartment not declared free from IHN, the Competent Authority of the importing country should require an international aquatic animal health certificate issued by the Competent Authority of the exporting country or a certified official approved by the importing country attesting that the procedures described in point 2 of Article 10.4.X. have been fulfilled.

---

### Article 10.5.X.

#### **Importation of disinfected eggs for aquaculture from a country, zone or compartment not declared free from infectious salmon anaemia**

1. When importing disinfected eggs of the species referred to in Article 10.5.2 for aquaculture from a country, zone or compartment not declared free from ISA, the Competent Authority of the importing country should assess the risk associated with at least:
  - a) the ISA virus status of the water used during the disinfection of the eggs
  - b) the level of infection with ISA virus in broodstock (ovarian fluid and milt); and
  - c) the temperature and pH of the water used for disinfection.

## Annex XXI (contd)

2. If the *Competent Authority* of the *importing country* concludes that the *importation* is acceptable, it should apply the following *risk mitigation measures* including:
- a) the *eggs* should be disinfected prior to importing, according to the methods described in Chapter 1.1.3. of the *Aquatic Manual* or those specified by the *Competent Authority* of the *importing country*, and
  - b) between *disinfection* and the import, *eggs* must be kept in specific pathogen free water.
3. When importing disinfected *eggs* of the species referred to in Article 10.5.2, for *aquaculture* from a *country, zone or compartment* not declared free from ISA, the *Competent Authority* of the *importing country* should require an *international aquatic animal health certificate* issued by the *Competent Authority* of the *exporting country* or a *certified official* approved by the *importing country* attesting that the procedures described Article 10.5.X. point 2 have been fulfilled.

---

Article 10.9.X

**Importation of disinfected eggs for *aquaculture* from a *country, zone or compartment* not declared free from viral haemorrhagic septicaemia**

1. When importing disinfected *eggs* of the species referred to in Article 10.9.2 for *aquaculture* from a *country, zone or compartment* not declared free from VHS, the *Competent Authority* of the *importing country* should assess the *risk* associated with at least:
- a) the VHS virus status of the water used during the disinfection of the *eggs*;
  - b) the level of *infection* with VHS virus in broodstock (ovarian fluid and milt); and
  - c) the temperature and pH of the water used for *disinfection*.
2. If the *Competent Authority* of the *importing country* concludes that the *importation* is acceptable, it should apply the following *risk mitigation measures* including:
- a) the *eggs* should be disinfected prior to importing, according to the methods described in Chapter 1.1.3. of the *Aquatic Manual* or those specified by the *Competent Authority* of the *importing country*, and
  - b) between *disinfection* and the import, *eggs* must be kept in specific pathogen free water.
3. When importing disinfected *eggs* of the species referred to in Article 10.9.2 for *aquaculture* from a *country, zone or compartment* not declared free from VHS, the *Competent Authority* of the *importing country* should require an *international aquatic animal health certificate* issued by the *Competent Authority* of the *exporting country* or a *certified official* approved by the *importing country* attesting that the procedures described Article 10.9.X. point 2 have been fulfilled.

-----  
 - text deleted

## CHAPTER 7.3.

**SLAUGHTER OF FARMED FISH  
FOR HUMAN CONSUMPTION**

## Article 7.3.1.

**Scope**

These recommendations apply to the slaughter of farmed fish species for human consumption.

These recommendations address the need to ensure the welfare of farmed fish, intended for human consumption, during pre-slaughter and slaughter processes, until they are dead.

This chapter describes general principles that should be applied to ensure the welfare of fish for slaughter and also applies to fish killed for disease control purposes and intended for human consumption. Specific measures applicable to emergency killing for disease control purposes not intended for human consumption are addressed in Chapter 7.4. Humane Killing for disease control purposes (under development).

As a general principle, fish should be stunned before killing, and the stunning method should ensure immediate and irreversible loss of consciousness. If the stunning is not irreversible, fish should be killed before consciousness is recovered.

## Article 7.3.2.

**Personnel**

Persons engaged in the handling, stunning and slaughter of fish play an important role in their welfare. Personnel handling fish for slaughter should be experienced and competent in the handling of fish, and understand their behaviour patterns as well as the underlying principles necessary to carry out their tasks. Some stunning and killing methods may pose a risk to the personnel, therefore training should cover occupational health and safety implications of any methods used.

## Article 7.3.3.

**Transport of fish for slaughter**

If fish are to be transported for slaughter, this should be done in accordance with the OIE recommendations on the welfare of farmed fish during transport (see Chapter 7.2.).

## Article 7.3.4.

**Design of facilities for holding fish prior to slaughter**

1. The holding facilities should be designed and specifically constructed to hold a certain fish species or group of fish species.
2. The holding facilities should be of a size that allows holding a certain number of fish for processing in a given timeframe without compromising the welfare of the fish.
3. Operations should be conducted with minimal injury and stress to the fish.

Annex XXII (contd)

4. The following recommendations may help to achieve this:
  - a) nets and tanks should be suitably designed to minimise physical injuries;
  - b) water quality should be suitable for the fish species and stocking density;
  - c) equipment for transferring fish, including pumps and pipes, should be appropriate to minimise injury.

Article 7.3.5.

### **Unloading, transferring and loading fish prior to slaughter**

1. Fish should be unloaded, transferred and loaded for slaughter under conditions that minimise injury and stress to the fish.
2. The following points should be considered:
  - a) Water quality should be assessed on arrival of fish prior to their unloading for slaughter, and corrective action taken as appropriate.
  - b) Where possible any injured or moribund fish should be separated and killed humanely.
  - c) The crowding periods of fish prior to slaughter should be as short and infrequent as possible;
  - d) The handling of fish during transfers should be minimised.
  - e) Where feasible, and when applicable, fish should be allowed to swim directly into a stunning device without handling to avoid handling stress.
  - f) Equipment used to handle fish, for example nets and dip nets, pumping devices and brailing devices, should be designed, constructed and operated to minimise physical injuries.
  - g) There should be a contingency plan to address emergencies and minimise stress during unloading, transferring and loading fish prior to slaughter.

Article 7.3.6.

### **Stunning and killing methods**

1. General considerations
  - a) The *Competent Authority* should approve the stunning and killing methods for the slaughter of fish. The choice of slaughter method should take account of species-specific information where available.
  - b) Equipment should be maintained and operated appropriately; it should be tested on a regular basis to ensure that performance is adequate.
  - c) Effective stunning should be verified by the absence of consciousness.
  - d) A backup stunning system is necessary. If mis-stunned, the fish should be re-stunned as soon as possible.

- e) Stunning should not take place if killing is likely to be delayed such that the fish will recover or partially recover consciousness.
- f) While unconsciousness may be difficult to recognise, signs of correct stunning include i) loss of respiratory movement (loss in opercular activity); ii) loss of visual evoked response (VER); iii) loss of vestibulo-ocular reflex (VOR, eye rolling).

## 2. Mechanical stunning and killing methods

- a) Percussive stunning is achieved by a blow of sufficient strength to the head applied above or immediately adjacent to the brain in order to damage the brain. Mechanical stunning may be achieved either manually or using specially developed equipment.
- b) Spiking or coring are irreversible stunning and killing methods of fish based on physical damage to the brain by inserting a spike or core into the brain.
- c) Shooting using a free bullet may be used for killing large fish (such as tuna). The fish may either be crowded in a net and shot in the head from the surface, or individual fish may be killed by shooting in the head from under the water (commonly called lupara).
- d) Mechanical stunning is generally irreversible if correctly applied.

## 3. Electrical stunning and killing methods

- a) Electrical stunning involves the application of an electrical current of sufficient strength, frequency and duration to cause immediate unconsciousness and insensibility of the fish. In fresh water, the water conductivity is essential to establish parameters of the electrical current suitable to ensure appropriate stunning.
- b) The electrical stunning device should be constructed and used for the specific fish species and their environment.
- c) Electrical stunning may be reversible. In such a case fish should be killed before consciousness is recovered.
- d) Fish should be confined beneath the surface of the water, and there should be a uniform distribution of electrical current in the stunning tank or chamber.
- f) In semi-dry electrical stunning systems, fish should enter the device head first to ensure rapid, painless and efficient stunning.

## 4. Other stunning and killing methods

The following other methods are known to be used: carbon dioxide (CO<sub>2</sub>) in holding water; chilling with ice and CO<sub>2</sub> in holding water; salt or ammonia baths; asphyxiation by removal from water; exsanguination without stunning. However, they have been shown to result in poor fish welfare. It is preferable to use the methods described in points 2., 3. and 4. of this Article, as appropriate to the fish species.

Article 7.3.7.

### **Application of some stunning methods for fish groups**

The following stunning methods enable humane killing for the following fish groups:

Annex XXII (contd)

- a) Percussive stunning: carp, catfish, salmonids, halibut;
- b) Spiking or coring: salmonids, tuna;
- c) Free bullet: tuna;
- d) Electrical stunning: carp, catfish, eel, salmonids, tilapia.

Article 7.3.8.

**Summary of some stunning methods for fish and their respective welfare issues**

A combination of methods described in the table below may be used.

Stunning/kill ing method	Specific method	Key fish welfare concerns/requirements	Advantages	Disadvantages
<b>Mechanical</b>	Percussive stunning	The blow should be of sufficient force and delivered above or adjacent to the brain in order to render immediate unconsciousness. Fish should be quickly removed from the water, restrained and given a quick blow to the head, delivered either manually by a club or by automated percussive stunning. The effectiveness of stunning should be checked, and fish be re-stunned if necessary. It can be a stun / killing method.	Immediate loss of consciousness. Well adapted to medium to large sized fish.	Hand operated equipment may be hampered by uncontrolled movement of the fish. Mis-stunning may result from a too weak blow. Injuries may occur. Manual percussive stunning is only practicable for the killing of a limited number of fish.
	Spiking or coring	The spike should be aimed on the skull in a position to penetrate the brain of the fish and the impact of the spike should produce immediate unconsciousness. Fish should be quickly removed from the water, restrained and the spike immediately inserted into the brain. It is a stun / killing method.	Immediate loss of consciousness. Well adapted to medium to large sized fish. For small tuna, spiking under the water avoids exposure of fish to air. The pineal window of tuna facilitates spiking for this species.	Inaccurate application may cause injuries. Difficult to apply if fish agitated. It is only practicable for the killing of a limited number of fish.
	Free bullet	The shot should be carefully aimed at the brain. The fish should be positioned correctly and the shooting range should be as short as practicable. It is a stun / killing method.	Immediate loss of consciousness. Well adapted to large sized fish (e.g. large tuna).	Shooting distance; calibre need to be adapted. Excessive crowding and noise of guns may cause stress reaction. Contamination of the working area due to release of body fluids may present a biosecurity risk. May be hazardous to operators.
<b>Electrical</b>	Electrical stunning	Involves the application of an electrical current of sufficient strength, frequency and duration to cause immediately unconsciousness. It can be a stun / killing method. Equipment should be designed and maintained correctly.	Immediate loss of consciousness. Well adapted to small to medium sized fish. Suitable for large numbers of fish, and the fish do not have to be removed from the water.	Difficult to standardise for all species. Optimal control parameters are unknown for some species. May be hazardous to operators.
	Semi-dry electrical stunning	The head of the fish should enter the system first so electricity is applied to the brain first. Involves the application of an electrical current of sufficient strength, frequency and duration to cause immediately unconsciousness. Equipment should be designed and maintained correctly.	Good visual control of stunning and the ability for re-stunning of individual fish.	Misplacement of the fish may result in improper stunning. Optimal control parameters are unknown for some species. Not suitable for mixed sizes of fish.

## CHAPTER 6.1.

**INTRODUCTION TO THE RECOMMENDATIONS FOR CONTROLLING ANTIMICROBIAL RESISTANCE**

## Article 6.1.

**Objective**

The purpose of chapters (6.2., 6.3., 6.4. under study) is to provide methodologies for OIE Members to appropriately address the emergence or spread of resistant bacteria from the use of antimicrobial agents in *aquatic animals* and to contain antimicrobial resistance through controlling the use of antimicrobial agents.

Antimicrobial agents are essential drugs for human and animal health and welfare. The OIE recognises the need for access to antimicrobial agents in veterinary medicine: antimicrobial agents are essential for treating, controlling and preventing infectious *diseases in aquatic animals*. The OIE therefore considers that ensuring continued access to effective antimicrobial agents is a priority.

The OIE recognises that antimicrobial resistance is a global public and *aquatic animal* health concern that is influenced by the usage of antimicrobial agents in humans, *aquatic animals* and elsewhere. Those working in the human, animal and plant sectors have a shared responsibility to prevent or minimise pressures for the selection of antimicrobial resistance factors in humans and *aquatic animals*. Arising from its mandate for the protection of animal health and food safety, the OIE developed these chapters to provide guidance to Members in regard to risks in the animal sector.

The application of *risk assessment* measures should be based on international standards on microbiological *risk analysis* and supported by sound data and information when available. The methodologies provided in these chapters should be consulted as part of the standard approach to prevent and reduce antimicrobial resistance.

---





## **GUIDANCE ON CONSIDERING SPECIES AS SUSCEPTIBLE TO A DISEASE**

Susceptible species as defined in the *Aquatic Code* means a species of *aquatic animal* in which *infection* has been demonstrated by natural *cases* or by experimental exposures to the *disease agent* that mimics the natural pathways for *infection*. Each *disease* chapter in the *Aquatic Code* and *Aquatic Manual* contains a list of currently known *susceptible species*. The scope of this Guideline is to provide criteria to determine which species should be listed.

Susceptibility should be assessed with consideration to:

### 1. Identification of the causative agent

Identification of the causative agent in accordance with methods described in the *Aquatic Manual*, is a prerequisite.

AND

### 2. Natural pathways

Evidence should be classified as natural occurrence, non-invasive experimental procedure, and invasive experimental procedure.

Natural occurrence, data from non-invasive experimental procedures and data from invasive experimental procedures that mimic the natural route of infection (for example, scarification of skin for transmission of EUS) should be considered as evidence of susceptibility.

AND

### 3. Criteria for infection

A combination of these criteria should be used to assess infection of a host species:

- i) presence of an infectious or a viable organism, in or on, the live aquatic animal;
- ii) evidence of multiplication or other development of the organism;
- iii) clinicopathological changes associated with the infection;
- iv) specific location of the pathogen.

The type of scientific data supporting the criteria will depend on the causative agent under consideration.

Examples of the occurrence of causative agents in non susceptible species may include PCR positive test results for a causative agent in a atypical species, e.g. KHV in skin of sturgeon; or in filter feeders, e.g. WSSV in rotifers, *Artemia*, or bivalves; or ISA virus in mussels.

The outcomes of this assessment could be definite, possible and unlikely. The decision to list a species as susceptible will be based on a finding that the evidence is definite.

## **References**

Scientific Opinion of the Panel on AHAW on a request from the European Commission on aquatic animal species susceptible to diseases listed in the Council Directive 2006/88/EC. The EFSA Journal (2008) 808, 1-145.

---



Original: English  
August 2009

**MEETING OF THE OIE AD HOC GROUP ON  
SAFETY OF COMMODITIES DERIVED FROM AQUATIC ANIMALS**

**Paris, 24-26 August 2009**

Dr Sarah Kahn, Head of the International Trade Department, on behalf of the Director General of the OIE, welcomed participants and thanked them for their ongoing support of the work of the OIE. The issue of safe commodities is particularly important to the OIE because it can provide a pathway for countries to participate in international trade without being obliged to eradicate, in the short term, significant diseases, a task that can be particularly difficult for developing countries. Dr Franck Berthe chaired the meeting.

The adopted agenda is provided in [Annex I](#) and members of the OIE *ad hoc* Group are listed in [Annex II](#).

The table shows a summary of all [Annexes](#) presented in this report:

<b>Annex number</b>	<b>Contents</b>
I	Adopted agenda
II	<i>Ad hoc</i> Group members
III (A) / III (B)	Disease X example Articles X.X.3; X.X.9; and X.X.11/12
IV	Amended text Article 1.5.6. Measures concerning international transport of aquatic animal disease agents and pathological material
V	EHNV: amended Articles 10.1.3;10.1.9; and 10.1.12 / commodity assessments
VI	Taura Syndrome Virus: amended Articles 9.4.3; 9.4.9; and 9.4.11 / commodity assessments
VII	Infection with <i>B. ostreae</i> : amended Articles 11.2.3;11.2.9; and 11.1.11 / commodity assessments
VIII	Amended Articles 5.3.1. and 5.3.2.
IX	New draft Articles 10.4.X.; 10.5.X.; 10.9.X. on importation of disinfected salmonid eggs

**1. Example Articles X.X.3, X.X.9, and X.X.12**

Comments were received from Australia, Chinese Taipei, European Union, Thailand and United States of America. The *ad hoc* Group reviewed these comments and amended the text accordingly. In addition the *ad hoc* Group made further amendments to the 3 Articles (X.X.3, X.X.9 and X.X.12) to clarify the purpose of each Article.

Annex XXV (contd)

Article X.X.3 addresses the importation of aquatic animal products considered to be safe for any purpose regardless of the disease status of the exporting country, zone or compartment.

Article X.X.9 addresses the importation of live aquatic animals and aquatic animal products for processing from a country, zone or compartment not declared free.

Article X.X.12 addresses the importation of live aquatic animals and aquatic animal products for retail trade for human consumption from a country, zone or compartment not declared free.

The *ad hoc* Group noted that the example Articles X.X.3; X.X.9; X.X.12 which use the SVC chapter as an example had been provided to illustrate the proposed changes to all disease chapters. The *ad hoc* Group recommended that this example instead be written in terms of a generic 'disease X' to make it clear this is an example that will be applied generically across all disease chapters.

In example Articles X.X.3 and X.X.12, theoretical commodities (e.g. commodity A, B and C) are listed as 'under study.'. The *ad hoc* Group recommended that all commodities currently listed in all the disease specific chapters be put 'under study' until the *ad hoc* Group has completed their assessments against the criteria in Articles 5.3.1 and 5.3.2. (adopted at the General Session in May 2009).

The *ad hoc* Group undertook an assessment of commodities listed under the current Article X.X.3, 1a) and 1b) for a fish disease (EHN), a crustacean disease (Taura syndrome) and a mollusc disease (infection with *B. ostreae*) (refer to Item 3 below).

The *ad hoc* Group recommended that the Aquatic Animal Health Standards Commission (AAC) consider the revised Articles X.X.3, X.X.9, and X.X.12 for possible adoption in May 2010 across all disease chapters in the *Aquatic Code*.

As quite a large number of amendments were made, the amended text in Annex III (A) is also provided as clean text in Annex III (B) to assist Members in reading and understanding these documents.

## **2. Measures concerning the international transport of aquatic animal disease agents and pathological material (Article 1.5.6.1)**

Comments were received from the European Union and the United States of America. The *ad hoc* Group reviewed these comments and amended the text accordingly.

The amended text is presented in Annex IV.

## **3. Assessment of commodities listed under the current Article X.X.3 points 1a) and 1b) for EHN, Taura syndrome and infection with *B. ostreae* using the criteria in Articles 5.3.1. and 5.3.2**

### **3.1. Example assessments**

The *ad hoc* Group undertook an assessment of commodities listed for a fish disease (EHN), a crustacean disease (Taura syndrome) and a mollusc disease (infection with *B. ostreae*). Commodities currently listed in Article X.X.3 point 1a) were assessed using criteria in Article 5.3.1, and commodities currently listed in Article X.X.3 point 1b) were assessed using criteria in Article 5.3.2 for these 3 diseases.

The assessments for EHN, Taura syndrome and infection with *B. ostreae* are presented in Annexes V, VI and VII, respectively, to provide Members with background information on these assessments.

### 3.2. Amendments to the Articles 5.3.1 and 5.3.2

In the process of conducting these assessments the *ad hoc* Group made amendments to the text of Article 5.3.1 and the text and criteria in Article 5.3.2.

Amendments to the text of Article 5.3.1 were editorial, to reflect proposed amendments in Article X.X.3.

Article 5.3.2 was amended to better address the purpose of Article X.X.12 (in fish chapters) / Article X.X.11 (in crustacean and mollusc chapters) which is to list commodities on the basis of their form and presentation, the expected volume of waste tissues generated by the consumer and the likelihood of viable disease agent in the waste. The text on ‘considerations for treatment’ (point 3b i-iii) of the commodity prior to importation was deleted from Article 5.3.2 because this aspect is assessed with viability of the disease agent in waste tissue (point 3). Treatment as a criterion to assess the safety of a commodity is already included in Article 5.3.1.

The amended Articles 5.3.1 and 5.3.2 are presented in Annex VIII for Member comment.

### 3.3. Articles 10.1.3, 10.1.9, 10.1.12 for EHN; Articles 9.4.3, 9.4.9, 9.4.11 for Taura syndrome; and Articles 11.2.3, 11.2.9, 11.2.11 for infection with *B. ostreae*

As a result of the example assessments (see Item 3.1.) the *ad hoc* Group proposed amendments to commodities listed in Articles X.X.3 (currently listed in Article X.X.3 1a) and X.X.11 / X.X.12 (currently listed in Article X.X.3 1b). In line with proposed changes to Articles X.X.3, X.X.9, and X.X.11 / X.X.12 (see Item 1), the amended Articles for these 3 diseases are provided in Annex V (EHN), Annex VI (Taura syndrome), and Annex VII (Infection with *B. ostreae*), respectively.

## 4. Review of Trade in Aquatic Animal Commodities

Dr Lahsen Ababouch presented an overview of the global trade in aquatic animal commodities. This was complemented by descriptions of imports in the EU and the export situation from Vietnam by Dr P. Rosado and Ms Phan Thi Van respectively.

The *ad hoc* Group noted that the commodities listed in the disease specific chapters (currently in Article X.X.3 1a and 1b) do not always reflect the reality of the international trade in aquatic commodities. Efforts will be made to use the commonly accepted commodity names in trade for future assessments. The *ad hoc* Group will assess only commodities that are known to be traded internationally.

## 5. Trade measures for disinfected salmonid eggs

The *ad hoc* Group developed a draft new Article on trade measures for disinfected salmonid eggs for three disease chapters: viral haemorrhagic septicaemia (VHS), infectious salmon anaemia (ISA) and infectious haematopoietic necrosis (IHN). These draft Articles make reference to Chapter 1.1.3 of the *Aquatic Manual*.

The *ad hoc* Group noted that information on true vertical transmission of EHN is needed before this Article could be included in the EHN chapter of the *Aquatic Code*.

Protocols for the disinfection of non salmonid eggs are needed before such an Article could be developed for the importation of disinfected eggs of non salmonids.

The draft text for a new Article on trade measures for disinfected salmonid eggs to be included in the disease chapters on VHS, ISA and IHN are presented in Annex IX for Member comments.

Annex XXV (contd)

**6. References to non-susceptible species in mollusc chapters**

The *ad hoc* Group recommended that the reference to non-susceptible species in Article X.X.3 point 1c of the *Aquatic Code* chapters on Infection with *B. ostreae*, *M. refringens* and *B. exitiosa* be moved to the relevant *Manual* chapters.

**7. Future work**

The *ad hoc* Group agreed on work to be done in advance of a possible further meeting.

---

.../Annexes

**MEETING OF THE OIE *AD HOC* GROUP ON  
SAFETY OF COMMODITIES DERIVED FROM AQUATIC ANIMALS**

**Paris, 24–26 August 2009**

---

**Adopted agenda**

**Welcome by Director General**

**Adoption of the agenda**

**1. *Aquatic Animal Health Code* – Members' comments**

1.1. Example Article X.X.X.3; X.X.X.9; X.X.X.12

1.2. Measures concerning international transport of aquatic animal disease agents and pathological material (Article 1.5.6.1. - new text)

**2. Assess commodities using Articles 5.3.1 and 5.3.2 (Chapter 5.3. Criteria to assess the safety of aquatic animal commodities) as listed in Article X.X.X. 3 1a) and 1b) for:**

2.1. Fish disease example - EHN

2.2. Mollusc disease example – Infection with *Bonamia ostreae*

2.3. Crustacean disease example - Taura syndrome

**3. Disinfection of salmonid eggs** - develop a new article for relevant disease chapters

**4. References to non-susceptible species**

**5. Review of trade in aquatic animal commodities**

**6. Any other business**

---





**MEETING OF THE OIE AD HOC GROUP ON  
SAFETY OF COMMODITIES DERIVED FROM AQUATIC ANIMALS**

**Paris, 24–26 August 2009**

**List of participants**

**MEMBERS OF THE AD HOC GROUP**

---

**Dr Franck Berthe** (*Chairperson*)

Senior Scientific Officer  
European Food Safety Authority -  
EFSA  
Animal Health and Animal Welfare unit  
Largo N. Palli 5/A, 43100 Parma  
ITALY  
Tel.: + 39 0521 036 870  
Fax: + 39 0521 036 0870  
[Franck.Berthe@efsa.europa.eu](mailto:Franck.Berthe@efsa.europa.eu)

**Dr Colin Johnston**

Principal Adviser, Aquatic Animal  
Diseases  
Investigation & Diagnostic Centres,  
Ministry of Agriculture & Forestry  
Biosecurity New Zealand  
PO Box 40742  
Wallaceville, Upper Hutt 5140  
New Zealand  
Tel: +64 4 894 5628  
Fax: +64 4 891 0234  
[Colin.Johnston@maf.govt.nz](mailto:Colin.Johnston@maf.govt.nz)

**Dr Kim C. Klotins**

Veterinary Epidemiologist  
Risk Assessment  
Aquatic Animal Health Division  
Canadian Food Inspection Agency  
8 Colonnade Rd.  
Ottawa, ON, Canada K1A 0Y9  
Tel: 613-221-1398  
Fax: 613-221-3173  
[Kim.klotins@inspection.gc.ca](mailto:Kim.klotins@inspection.gc.ca)

**Dr Birgit Oidtmann**

Dr Med Vet, Habilitation, MRCVS  
Epidemiologist  
Cefas Weymouth Laboratory  
Barrack Road, The Nothe  
Weymouth, Dorset DT4 8UB  
UK  
Tel: 0044/1305/206661  
Fax: 0044/1305/206601  
[birgit.oidtmann@cefasc.co.uk](mailto:birgit.oidtmann@cefasc.co.uk)

**Dr Pedro Rosado Martin**

European Commission  
DG SANCO-D1  
Rue Froissart 101, F101 B-03/76  
1040 Brussels  
Belgium  
+32-2-2958916  
[pedro.rosado-martin@ec.europa.eu](mailto:pedro.rosado-martin@ec.europa.eu)

**Phan Thi Van**

Director  
Centre for Environment and  
Disease Monitoring in Aquaculture  
(CEDMA)  
Research Institute for Aquaculture  
No.1 (RIA1)  
Dinh Bang - Tu Son - Bac ninh -  
Vietnam  
Tel/fax: +84 (0)913236939  
[phanthivan\\_vn@yahoo.com](mailto:phanthivan_vn@yahoo.com);  
[phanvan@ria1.org](mailto:phanvan@ria1.org)

**Dr Lahsen Ababouch**

Chief  
Fish Utilization and Marketing Service  
Fish Products and Industry Divison  
Fisheries and Aquaculture Department  
Viale delle terme di Caracalla  
00153 Rome  
ITALY  
Fax: +39 06 57055188  
Tel: + 39 06 57054157  
E-mail: [Lahsen.Ababouch@fao.org](mailto:Lahsen.Ababouch@fao.org)

Annex XXV (contd)

Annex II (contd)

## **OIE HEADQUARTERS**

---

**Dr Bernard Vallat**  
Director General  
OIE  
12, rue de Prony  
75017 Paris  
FRANCE  
Tel.: 33 - (0)1 44 15 18 88  
Fax: 33 - (0)1 42 67 09 87  
E-mail: [oiie@oiie.int](mailto:oiie@oiie.int)

**Dr Sarah Kahn**  
Head  
International Trade Department  
OIE  
E-mail: [s.kahn@oiie.int](mailto:s.kahn@oiie.int)

**Dr Gillian Mylrea**  
Chargée de mission  
International Trade Department  
OIE  
E-mail: [g.mylrea@oiie.int](mailto:g.mylrea@oiie.int)

---

REVISED ARTICLES ~~2.X.X.3. AND 2.X.X.9.~~  
AND ~~2.X.X.12.~~

~~USING THE SVC CHAPTER ARTICLES AS AN EXAMPLE~~

**AN EXAMPLE (DISEASE X) TO BE APPLIED ACROSS  
ALL DISEASE CHAPTERS**

Article ~~XX.32.1.4.3.~~

**Commodities-Importation or transit of aquatic animal products for any purpose regardless of the Disease X status of the exporting country, zone or compartment**

1. ~~When authorising the importation or transit of the following commodities, the Competent Authorities should not require any Disease X SVC related conditions, regardless of the SVC Disease X status of the exporting country, zone or compartment when authorising the importation or transit of the following commodities from the species referred to in Article XX.2.2.1.4.2. intended for any purpose and complying with Article 5.3.1.:~~

~~[i] commodities treated in a manner that inactivates the disease agent (e.g. leather made from fish skin-aquatic product A~~

~~; ii) pasteurised products-aquatic product B~~

~~iii) and some ready to eat meals; aquatic product C~~

~~and fish oil and fish meal intended for use in feed; ] (under study)~~

~~ii) biological samples preserved for diagnostic applications in such a manner as to inactivate the disease agent.~~

- b) ~~The following commodities destined for human consumption from the species referred to in Article 2.1.4.2. which have been prepared and packaged for direct retail trade:~~

~~i) eviscerated fish (chilled or frozen);~~

~~ii) fillets or cutlets (chilled or frozen);~~

~~iii) dried eviscerated fish (including air dried, flame dried and sun dried).~~

~~For the commodities referred to in point 1b), Members may wish to consider introducing internal measures to prevent the commodity being used for any purpose other than for human consumption.~~

2. When authorising the importation or transit of commodities of a species referred to in Article ~~XX.22.1.4.2.~~, other than those referred to in point 1 of Article ~~XX.32.1.4.3.~~, the Competent Authorities should require the conditions prescribed in Articles ~~XX.7.2.1.4.7. to XX.12.2.1.4.12.~~ relevant to the SVC Disease X status of the exporting country, zone or compartment.

Annex XXV (contd)Annex III (A) (contd)

3. When considering the importation/ or transit of a commodity from an *exporting country, zone or compartment* not declared free of SVC Disease X of a live commodity from a species not covered in Article X.X.2.2.1.4.2. but which could reasonably be expected to pose a risk of transmission ~~be a potential mechanical vector/fomite~~ for Disease X/SVC, the *Competent Authorities* should conduct a *risk analysis* in accordance with the recommendations in the *Aquatic Code*. The *exporting country* should be informed of the outcome of this assessment.

[...]

Article 10.8.2.1.4.9.

**Importation of live aquatic animals and aquatic animal products for processing for human consumption from a country, zone or compartment not declared free from Disease X**

When importing, for processing for human consumption, live aquatic animals and aquatic animal products of the species referred to in Article X.X.2.2.1.4.2. ~~and aquatic animal products~~ from a country, zone or compartment not declared free from Disease X/SVC, the *Competent Authority* of the *importing country* should assess the *risk* and, if justified, require that:

1. the consignment is delivered directly to and held in quarantine or containment facilities for ~~slaughter and~~ processing to one of the products referred to in point 1 of Article X.X.3.2.1.4.3., or products described in point 1 2 of Article X.X.12.2.1.4.12., or other products authorised by the *Competent Authority*, and
2. all effluent and waste material from the processing are treated in a manner that ensures inactivation of Disease X agent/SVCV or is disposed in a manner that prevents contact of waste with susceptible species.

For these commodities Members may wish to consider introducing internal measures to address the risks of prevent associated with the such commodities being used for any purpose other than for human consumption.

~~This Article does not apply to commodities referred to in point 1 of Article 2.1.4.3. or products described in point 1 2 of Article 2.1.4.12.~~

[...]

Article X.X.12.2.1.4.12. (fish chapters) / Article X.X.11. (mollusc and crustacean chapters)

**Importation of live aquatic animals and aquatic animal products for retail trade for human consumption from a country, zone or compartment not declared free from Disease X spring viraemia of carp**

1. ~~When authorising the importation or transit of the following commodities which have been prepared and packaged for direct retail trade, Competent Authorities should not require any Disease X/SVC related conditions, regardless of the Disease X/SVC status of the exporting country, zone or compartment when authorising the importation or transit of the following commodities which have been prepared and packaged for retail trade and complying with Article 5.3.2.: The risk posed by the following products destined for human consumption from the species referred to in Article 2.1.4.2. which have been prepared and packaged for direct retail trade is considered negligible:~~

Annex XXV (contd)

Annex III (A) (contd)

- [ i) ~~viscerated fish (chilled or frozen); commodity 1~~
- ii) ~~fillets or cutlets (chilled or frozen); commodity 2~~
- iii) ~~dried viscerated fish (including air dried, flame dried and sun dried); commodity 3 ] (under study)~~

For these commodities Members may wish to consider introducing internal measures to address the risks ~~prevent~~ associated with the commodity being used for any purpose other than for human consumption.

- 2. When importing live aquatic animals or aquatic animal products, other than those referred to in point 1 above, of the species referred to in Article ~~XX.2. 2.1.4.2.~~ from a country, zone or compartment not declared free from Disease X SVC, the Competent Authority of the importing country should assess the risk and apply appropriate risk mitigation measures.
- 3. In the case of dead fish, whether ~~viscerated~~ or ~~uneviscerated~~, such ~~r~~Risk mitigation measures may include:
  - 1. a) ~~the direct delivery into and holding of the consignment in biosecure/ quarantine facilities for processing to one of the products referred to in point 1 of Article 10.8.3.2.1.4.3., or products described in point 1 2 of this Article~~, or other products authorised by the Competent Authority;
  - 2. b) ~~the treatment of all effluent and waste material in a manner that ensures inactivation of SVCV or disposed in a manner that prevents contact of waste with susceptible species.~~

This Article does not apply to commodities referred to in point 1 of Article ~~2.1.4.3.~~ or products described in point 1 2 of Article 2.1.4.12.

-----  
 - text deleted



REVISED ARTICLES X.X.3. AND X.X.9.  
AND X.X.12.

AN EXAMPLE (DISEASE X) TO BE APPLIED ACROSS  
ALL DISEASE CHAPTERS

Article X.X.3.

**Importation or transit of aquatic animal products for any purpose regardless of the Disease X status of the exporting country, zone or compartment**

1. *Competent Authorities* should not require any Disease X related conditions, regardless of the Disease X status of the *exporting country, zone or compartment* when authorising the importation or transit of the following *commodities* from the species referred to in Article X.X.2. intended for any purpose and complying with Article 5.3.1.:
  - [ i) aquatic animal product A
  - ii) aquatic animal product B
  - iii) aquatic animal product C ](under study)
2. When authorising the importation or transit of *commodities* of a species referred to in Article X.X.2., other than those referred to in point 1 of Article X.X.3., *Competent Authorities* should require the conditions prescribed in Articles X.X.7. to X.X.12. relevant to the Disease X status of the *exporting country, zone or compartment*.
3. When considering the importation or transit of a *commodity* from an *exporting country, zone or compartment* not declared free of Disease X from a species not covered in Article X.X.2. but which could reasonably be expected to pose a risk of transmission for Disease X, *Competent Authorities* should conduct a *risk analysis* in accordance with the recommendations in the *Aquatic Code*. The *exporting country* should be informed of the outcome of this assessment.

[...]

Article X.X.9.

**Importation of live aquatic animals and aquatic animal products for processing for human consumption from a country, zone or compartment not declared free from Disease X**

When importing, for processing for human consumption, live *aquatic animals* and *aquatic animal products* of the species referred to in Article X.X.2. from a country, *zone or compartment* not declared free from Disease X, the *Competent Authority* of the *importing country* should assess the *risk* and, if justified, require that:

1. the consignment is delivered directly to and held in *quarantine* or containment facilities for processing to one of the products referred to in point 1 of Article X.X.3., or products described in point 1 of Article X.X.12., or other products authorised by the *Competent Authority*, and
2. all effluent and waste material from the processing are treated in a manner that ensures inactivation of Disease agent X or is disposed in a manner that prevents contact of waste with susceptible species.

Annex XXV (contd)

Annex III (B) (contd)

For these *commodities* Members may wish to consider introducing internal measures to address the *risks* associated with the *commodity* being used for any purpose other than for human consumption.

[...]

Article X.X.12. (fish chapters) /Article X.X.11. (mollusc and crustacean chapters)

**Importation of live aquatic animals and aquatic animal products for retail trade for human consumption from a country, zone or compartment not declared free from Disease X**

1. *Competent Authorities* should not require any Disease X related conditions, regardless of the Disease X status of the *exporting country, zone or compartment* when authorising the importation or transit of the following *commodities* which have been prepared and packaged for retail trade and complying with Article 5.3.2.:

- [ i) commodity 1
- ii) commodity 2
- iii) commodity 3 ] (under study)

For these *commodities* Members may wish to consider introducing internal measures to address the *risks* associated with the *commodity* being used for any purpose other than for human consumption.

2. When importing *live aquatic animals or aquatic animal products*, other than those referred to in point 1 above, of the species referred to in Article X.X.2. from a country, *zone* or *compartment* not declared free from Disease X, the *Competent Authority* of the *importing country* should assess the *risk* and apply appropriate *risk* mitigation measures.

---

-----  
- text deleted



## CHAPTER 1.5.6.

**MEASURES CONCERNING INTERNATIONAL  
TRANSPORT OF AQUATIC ANIMAL DISEASE AGENTS  
AND PATHOLOGICAL MATERIAL**

## Article 1.5.6.1.

**Introduction**

There is the *risk* that *disease* may occur as a result of the accidental release of *aquatic animal* pathogens during international transport of packaged materials. Such pathogens may already occur in the country or they may have been imported deliberately or inadvertently. It is therefore necessary to have in place measures to prevent their accidental release. These measures may be applied at national borders by prohibiting or controlling the importation of specified *aquatic animal* pathogens or *pathological material*, which may contain them.

Competent Authorities should not require sanitary measures for biological samples preserved for diagnostic applications that are treated in such a manner as to inactivate the disease agent and will not cause aquatic animal disease.

## Article 1.5.6.2.

[...]



**Including:****Amended Articles 10.1.3., 10.1.9. and 10.1.12.****Commodity assessments for Articles 10.1.3. and 10.2.12.**

## CHAPTER 10.1.

## EPIZOOTIC HAEMATOPOIETIC NECROSIS

[...]

Article 10.1.3.

**~~Commodities~~–Importation or transit of aquatic animal products for any purpose regardless of the EHN status of the exporting country, zone or compartment**

1. ~~When authorising the importation or transit of the following commodities, the Competent Authorities should not require any EHN related conditions, regardless of the EHN status of the exporting country, zone or compartment~~ when authorising the importation or transit of the following commodities from the species referred to in Article 10.1.2. intended for any purpose and complying with Article 5.3.1.:
  - a) ~~From the species referred to in Article 10.1.2. intended for any purpose:~~
    - i) ~~commodities treated in a manner that inactivates the disease agent e.g. fish skin~~ leather made from fish skin;
    - ii) pasteurised products and some ready to eat meals; and
    - iii) fish oil; and
    - iv) fish meal. intended for use in feed; (under study)
    - ii) biological samples preserved for diagnostic applications in such a manner as to inactivate the disease agent.
  - b) ~~The following commodities destined for human consumption from the species referred to in Article 10.1.2. which have been prepared and packaged for direct retail trade:~~
    - i) ~~eviscerated fish (chilled or frozen);~~
    - ii) ~~fillets or cutlets (chilled or frozen);~~
    - iii) ~~dried eviscerated fish (including air dried, flame dried and sun dried).~~

Annex XXV (contd)Annex V (contd)

~~For the *commodities* referred to in point 1b), OIE Members may wish to consider introducing internal measures to address the *risks* associated with the *commodity* being used for any purpose other than for human consumption.~~

2. When authorising the importation or transit of *commodities* of a species referred to in Article 10.1.2., other than those referred to in point 1 of Article 10.1.3., ~~the~~ *Competent Authorities* should require the conditions prescribed in Articles 10.1.7. to 10.1.12. relevant to the EHN status of the *exporting country, zone* or *compartment*.
3. When considering the importation ~~or transit~~ of a commodity from an *exporting country, zone* or *compartment* not declared free of EHN ~~of a live commodity~~ from a species not covered in Article 10.1.2. but which could reasonably be expected to pose a risk of transmission ~~be a potential mechanical vector~~ for EHN, ~~the~~ *Competent Authorities* should conduct a *risk analysis* in accordance with the recommendations in the *Aquatic Code*. The *exporting country* should be informed of the outcome of this assessment.

[...]

Article 10.1.9.

**Importation of live aquatic animals and aquatic animal products for processing for human consumption from a country, zone or compartment not declared free from epizootic haematopoietic necrosis**

When importing, for processing for human consumption, live *aquatic animals* and aquatic animal products of the species referred to in Article 10.1.2. from a country, *zone* or *compartment* not declared free from EHN, the *Competent Authority* of the *importing country* should assess the *risk* and, if justified, require that:

1. the consignment ~~be~~ is delivered directly to and held in *quarantine* or containment facilities for ~~slaughter and~~ processing to one of the products referred to in point 1 of Article 10.1.3., or products described in point 1 of Article 10.1.12., or other products authorised by the *Competent Authority*; and
2. all effluent and waste material from the processing are treated in a manner that ensures inactivation of EHN or is disposed in a manner that prevents contact of waste with susceptible species.

~~For these *commodities* OIE Members may wish to consider introducing internal measures to address the risks associated with the commodity prevent such *commodities* being used for any purpose other than for human consumption.~~

~~This Article does not apply to *commodities* referred to in point 1 of Article 10.1.3.~~

[...]

Article 10.1.12.

**Importation of live aquatic animals and aquatic animal products for retail trade for human consumption from a country, zone or compartment not declared free from epizootic haematopoietic necrosis**

Annex XXV (contd)

Annex V (contd)

1. Competent Authorities should not require any EHV related conditions, regardless of the EHV status of the exporting country, zone or compartment when authorising the importation or transit of the following commodities which have been prepared and packaged for retail trade and complying with Article 5.3.2.:

i) ~~viscerated fish (chilled or frozen);~~

ii) ~~fillets or steaks outlets (chilled or frozen); and~~

iii) ~~artificially dried viscerated fish (including air dried, flame dried and sun dried).-~~ (under study)

For these commodities Members may wish to consider introducing internal measures to address the risks associated with the commodity being used for any purpose other than for human consumption.

2. When importing live aquatic animals and aquatic animal products other than those referred to in point 1 above, of the species referred to in Article 10.1.2. from a country, zone or compartment not declared free from EHV, the *Competent Authority* of the *importing country* should assess the *risk* and apply appropriate *risk* mitigation measures.

~~In the case of dead fish, whether *viscerated* or *unviscerated*, such *risk* mitigation measures may include:~~

- ~~1. the direct delivery into and holding of the consignment in facilities for processing to one of the products referred to in point 1 of Article 10.1.3. or other products authorised by the *Competent Authority*;~~
- ~~2. the treatment of all effluent and waste material in a manner that ensures inactivation of EHNIV.~~

~~This Article does not apply to *commodities* referred to in point 1 of Article 10.1.3.~~

-----  
- text deleted

Annex XXV (contd)

Annex V (contd)

## COMMODITY ASSESSMENTS

### PART I:

#### Epizootic haematopoietic necrosis (EHN) assessments using amended Criteria in Article 5.3.1. (refer to Annex VIII)

Commodities that have been assessed are those currently in the *Aquatic Code* (Article 10.1.3. point 1a) and that are proposed for inclusion in the amended Article 10.1.3. for EHN:

'a) From the species referred to in Article 10.1.2. intended for any purpose:

i) commodities treated in a manner that inactivates the disease agent e.g. leather made from fish skin, pasteurised products and some ready-to-eat meals; and fish oil and fish meal intended for use in feed;'

Susceptible species currently listed are redbfin perch (*Perca fluviatilis*) and rainbow trout (*Oncorhynchus mykiss*).

#### Assessment for: Fish skin leather

<b>Commodity under consideration</b>		Fish skin leather	
<b>Criteria 5.3.1.</b>		<b>Assessment</b>	
1.	<b>Absence of disease agent in the traded commodity:</b>		
1a.	<i>There is strong evidence that the disease agent is not present in the tissues from which the commodity is derived</i>	The EHN virus can be found in skin (Redacliff and Whittington, 1996).	No
AND			
1b.	<i>The water (including ice) used to process or transport the commodity is not contaminated with the disease agent and the processing prevents cross contamination of the commodity to be traded</i>	Water is used to process the leather but the final product is dry and not transported in water.	NA
OR			
2.	<b>Even if the disease agent is present in, or contaminates in the tissues from which the commodity is derived, the treatment or processing to produce the commodity to be traded inactivates the disease agent:</b>		
2a.	<i>Physical (e.g. temperature, drying, smoking)</i>		
AND/OR			
2b.	<i>Chemical (e.g. iodine, pH, salt, smoke)</i>	Skin is exposed to alkaline metal sulphide, solvents, proteases, acid pH 1.5-4, chromium or other tanning solutions and dyes. The final leather product is usually pH <5. Each step takes between 15 minutes to 24 hours in a commercial setting (Pocket Book for the Leather Technologist 4 <sup>th</sup> edition). pH <4 or >12 for 1 hour will inactivate EHN virus (Langdon 1989).	Yes
AND/OR			
2c.	<i>Biological (e.g. fermentation).</i>		
Conclusion	EHN virus will not survive this process and <b>fish skin leather</b> is therefore eligible for inclusion in Article 10.1.3. point 1.		

Annex XXV (contd)Annex V (contd)**Assessment for: Pasteurised fish products**

<b>Commodity under consideration</b>		Pasteurised fish products	
<b>Criteria 5.3.1.</b>		<b>Assessment</b>	
<b>1.</b>	<b>Absence of disease agent in the traded commodity:</b>		
1a.	<i>There is strong evidence that the disease agent is not present in the tissues from which the commodity is derived</i>	EHN virus is present in muscle and other edible tissues (Jensen, Ersboll, Ariel 2008).	No.
AND			
1b.	<i>The water (including ice) used to process or transport the commodity is not contaminated with the disease agent and the processing prevents cross contamination of the commodity to be traded</i>	Water is used to process the product but the water is potable and the final product is sealed.	NA
OR			
<b>2.</b>	<b>Even if the disease agent is present in, or contaminates in the tissues from which the commodity is derived, the treatment or processing to produce the commodity to be traded inactivates the disease agent:</b>		
2a.	<i>Physical (e.g. temperature, drying, smoking)</i>	Pasteurisation involves heating at 63°C for 30 minutes (or equivalent). EHN virus is inactivated after 15minutes at 60°C; (Langdon 1989).	
AND/OR			
2b.	<i>Chemical (e.g. iodine, pH, salt, smoke)</i>		
AND/OR			
2c.	<i>Biological (e.g. fermentation).</i>		
Conclusion	EHN virus will not survive this process and pasteurised fish products are therefore eligible for inclusion in Article 10.1.3. point 1.		

Annex XXV (contd)Annex V (contd)**Assessment for: Fish oil and fish meal**

<b>Commodity under consideration</b>		Fish oil and fish meal	
<b>Criteria 5.3.1.</b>		<b>Assessment</b>	
<b>1.</b>	<b>Absence of disease agent in the traded commodity:</b>		
1a.	<i>There is strong evidence that the disease agent is not present in the tissues from which the commodity is derived</i>	EHN virus occurs in multiple tissues in infected fish. Fish oil is derived from whole fish or by-products of processing.	No
<b>AND</b>			
1b.	<i>The water (including ice) used to process or transport the commodity is not contaminated with the disease agent and the processing prevents cross contamination of the commodity to be traded</i>	If the fish are infected then the water is likely to be contaminated.	No
<b>OR</b>			
<b>2.</b>	<b>Even if the disease agent is present in, or contaminates in the tissues from which the commodity is derived, the treatment or processing to produce the commodity to be traded inactivates the disease agent:</b>		
2a.	<i>Physical (e.g. temperature, drying, smoking)</i>	During production, fish oil and fish meal undergoes multiple heat treatments and the final water content of the product is extremely low. Raw material is cooked (may be pre-heated to 50-60°C before cooking at temperatures of 95-100°C for 15-20 minutes. For energy cost reasons and nutritional content, some processors use 80-85°C for 20 minutes). Cooked material is pressed to produce press liquor and presscake that can be dried (75-80°C, =30 minutes) and milled to presscake meal. Press liquor is heated to 90-95°C, which produces oil and stick-water. Oil is purified with hot water (at 90°C). Stickwater is evaporated at =100°C (<130°C) and the resulting fish solubles are added to the presscake. Presscake + fish soluble mix dried at 75-80°C for =30 minutes to reduce water content to =12%. This is then milled to whole fishmeal.	
<b>AND/OR</b>			
2b.	<i>Chemical (e.g. iodine, pH, salt, smoke)</i>		
<b>AND/OR</b>			
2c.	<i>Biological (e.g. fermentation).</i>		
<b>Conclusion</b>	EHN virus will not survive this process and fish oil and fish meal are therefore eligible for inclusion in Article 10.1.3. point 1.		



Annex XXV (contd)Annex V (contd)**REFERENCES**

REDACLIFF AND WHITTINGTON (1996). Pathology of epizootic haematopoietic necrosis virus (EHNV) infection in rainbow trout (*Oncorhynchus mykiss* Walbaum) and redfin perch (*Perca fluviatilis* L). *J. Comp. Pathology*. Volume 115, Issue 2, 103–115.

LANGDON (1989). Experimental transmission and pathogenicity of epizootic haematopoietic necrosis virus (EHNV) in redfin perch, *Perca fluviatilis* L., and 11 other teleosts. *J. Fish Dis.*, 12, 295–310).

JENSEN, ERSBOLL, AND ARIEL (2008). Challenge studies of European stock of redfin perch, *Perca fluviatilis* L., and rainbow trout, *Oncorhynchus mykiss* (Walbaum), with epizootic haematopoietic necrosis virus. *Journal of Fish Diseases*. In press

POCKET BOOK FOR THE LEATHER TECHNOLOGIST 4TH EDITION; BASF, Ludwigshafen, Germany <http://visdombasferm.com/lp/Blue%20book.pdf>.

**PART II:****Epizootic haematopoietic necrosis (EHN) assessments using amended Criteria in Article 5.3.2. (refer to Annex VIII)**

Commodities to be assessed are those currently in the *Aquatic Code* (Article 10.1.3. point 1b) and that are proposed for inclusion in the amended Article 10.1.12. for EHN:

*'The following commodities destined for human consumption from the species referred to in Article 10.1.2. which have been prepared and packaged for direct retail trade:*

1. *eviscerated fish (chilled or frozen);*
2. *fillets or cutlets (chilled or frozen);*
3. *dried eviscerated fish (including air dried, flame dried and sun dried).'*

Susceptible species currently listed are redfin perch (*Perca fluviatilis*) and rainbow trout (*Oncorhynchus mykiss*).

**Assessment for: eviscerated fish (chilled or frozen)**

Commodity under consideration		eviscerated fish (chilled or frozen)	
Criteria 5.3.2.		Assessment	
1.	<i>the aquatic animal product is prepared and packaged for direct retail trade for human consumption</i>	It is part of the commodity definition	Y e s
AND EITHER			
2.	<i>It includes only a small amount of waste tissues</i>	Wastes include head, backbone and skin	N o
OR			
3.	<i>the disease agent is not normally found in the waste tissues</i>	EHN virus can be present in gills and skin (Redacliff and Whittington, 1996) and brain (Langdon, Humphrey and Williams 1988). EHNV can persist in frozen fish tissues for more than 2 years and EHN virus can persist in chilled fish tissues for more than 1 week (Langdon, 1989).	N o
<b>Conclusion</b>	Eviscerated fish (chilled or frozen) that are prepared and packaged for retail trade for human consumption may produce amounts of wastes that cannot be considered small; the disease agent may be found in the waste (skin and gills). Therefore, this product is not considered eligible for inclusion in the proposed Article 10.1.12. for EHN.		

Annex XXV (contd)Annex V (contd)**Assessment for fillets or ~~cutlets~~ steaks (chilled or frozen)**

<b>Commodity under consideration</b>		Fillets or <del>cutlets</del> steaks (chilled or frozen)
<b>Criteria 5.3.2.</b>		<b>Assessment</b>
1.	<i>the aquatic animal product is prepared and packaged for direct retail trade for human consumption</i>	It is part of the commodity definition.
AND EITHER		
2.	<i>It includes only a small amount of waste tissues</i>	Wastes include skin and bones.
OR		
3.	<i>the disease agent is not normally found in the waste tissues</i>	Virus can be present in skin (Redacliff and Whittington, 1996). EHN virus can persist in frozen fish tissues for more than 2 years and EHN virus can persist in chilled fish tissues for more than 1 week (Langdon, 1989).
<b>Conclusion</b>	Fillets or <del>cutlets</del> steaks (chilled or frozen) that are prepared and packaged for retail trade for human consumption may produce small amounts of wastes. Therefore, this product is considered to be eligible for inclusion in the proposed Article 10.1.12. for EHN.	

**Assessment for: naturally dried eviscerated fish (~~including air dried, flame dried and sun dried~~)**

**NOTE:** The assessment for the listed commodity in the *Aquatic Code*: 'dried eviscerated fish (including air dried, flame dried and sun dried)' does not describe a single traded commodity. Therefore, this assessment has been separated into the commonly traded commodities: naturally dried eviscerated fish and artificially dried eviscerated fish.

<b>Commodity under consideration</b>		<u>naturally</u> dried eviscerated fish ( <del>including air dried, flame dried and sun dried</del> )
<b>Criteria 5.3.2.</b>		<b>Assessment</b>
1.	<i>the aquatic animal product is prepared and packaged for direct retail trade for human consumption</i>	It is part of the commodity definition.
AND EITHER		
2.	<i>It includes only a small amount of waste tissues</i>	Waste includes head, backbone and skin.
OR		
3.	<i>the disease agent is not normally found in the waste tissues</i>	Virus can be present in skin (Redacliff and Whittington, 1996) and brain (Langdon, Humphrey and Williams 1988).
<b>Conclusion</b>	<u>Naturally</u> dried eviscerated fish ( <del>including air dried, flame dried and sun dried</del> ) that are prepared and packaged for retail trade for human consumption may produce amounts of wastes that cannot be considered small; the disease agent may be found in the waste tissues. Therefore, this product is not considered eligible for inclusion in the proposed Article 10.1.12. for EHN.	

Annex XXV (contd)

Annex V (contd)

Assessment for: artificially dried eviscerated fish (~~including air dried, flame dried and sun dried~~)

<b>Commodity under consideration</b>		<u>artificially</u> dried eviscerated fish ( <del>including air dried, flame dried and sun dried</del> )	
<b>Criteria 5.3.2.</b>		<b>Assessment</b>	
1.	<i>the aquatic animal product is prepared and packaged for direct retail trade for human consumption</i>	It is part of the commodity definition	Y e s
AND EITHER			
2.	<i>It includes only a small amount of waste tissues</i>	Waste includes head, backbone and skin	N o
OR			
3.	<i>the disease agent is not normally found in the waste tissues</i>	Virus can be present in skin (Redacliff and Whittington, 1996) and brain (Langdon, Humphrey and Williams 1988). Temperature for artificially dried is greater than 100°C for at least 30 minutes.	Y e s
<b>Conclusion</b>	<u>Artificially</u> dried eviscerated fish ( <del>including air dried, flame dried and sun dried</del> ) that are prepared and packaged for retail trade for human consumption may produce amounts of wastes that cannot be considered small; the disease agent is normally found in the waste tissues but processing prior to importation inactivates the disease agent. Therefore, this product is considered eligible for inclusion in the proposed Article 10.1.12. for EHN. However, it may be eligible for Article 10.1.3. and such an assessment should be performed.		

## REFERENCES

REDACLIFF AND WHITTINGTON (1996). Pathology of epizootic haematopoietic necrosis virus (EHN) infection in rainbow trout (*Oncorhynchus mykiss* Walbaum) and redfin perch (*Perca fluviatilis* L). *J. Comp. Pathology*. Volume 115, Issue 2, 103–115.

LANGDON (1989). Experimental transmission and pathogenicity of epizootic haematopoietic necrosis virus (EHN) in redfin perch, *Perca fluviatilis* L., and 11 other teleosts. *J. Fish Dis.*, 12, 295–310).

LANGDON, HUMPHREY AND WILLIAMS (1988). Outbreaks of an EHN-like iridovirus in cultured rainbow trout, *Salmo gairdneri* Richardson, in Australia. *J. Fish Dis.*, 11, 93–96.

WHITTINGTON, KEARNS, HYATT, HENGSTBERGER AND RUTZOU (1996). Spread of epizootic haematopoietic necrosis virus (EHN) in redfin perch (*Perca fluviatilis*) in southern Australia. *Aust. Vet. J.*, 73, 112–114.



**Including:****Amended ARTICLES 9.4.3; 9.4.9; 9.4.12.****Commodity assessments for Articles 9.4.3. and 9.4.11.**

## CHAPTER 9.4.

## TAURA SYNDROME

[...]

Article 9.4.3.

**Commodities Importation or transit of aquatic animal products for any purpose regardless of the Taura Syndrome status of the exporting country, zone or compartment**

1. ~~When authorising the importation or transit of the following commodities, the Competent Authorities should not require any TS related conditions, regardless of the TS status of the exporting country, zone or compartment when authorising the importation or transit of the following commodities from the species referred to in Article 9.2.2. intended for any purpose and complying with Article 5.3.1.:~~

a) ~~For the species referred to in Article 9.4.2. intended for any purpose:~~

~~i) commodities treated in a manner that inactivates the disease agent e.g. boiled-cooked products~~

~~ii) canned products; or pasteurised products and some ready to eat meals; and~~

~~iii) crustacean oil; and~~

~~iv) crustacean meal intended for use in feed;~~

~~v) chemically extracted chitin.~~

~~vi) crustacean products made non-infectious through processing as dry feed (e.g. pelleted or extruded feed); (under study)~~

~~vi) biological samples preserved for diagnostic applications in such a manner as to inactivate the disease agent.~~

b) ~~{The following products destined for human consumption from species referred to in Article 9.4.2. which have been prepared and packaged for direct retail trade:~~

~~For the commodities listed in point 1b), OIE Members may wish to consider introducing internal measures to address the risks associated with the commodity being used for any purpose other than for human consumption. (under study)}~~

2. When authorising the importation or transit of the commodities of a species referred to in Article 9.4.2., other than those listed in point 1 of Article 9.4.3., ~~the~~ Competent Authorities should require the conditions prescribed in Articles 9.4.7. to 9.4.11. relevant to the TS status of the exporting country, zone or compartment.

Annex XXV (contd)Annex VI (contd)

3. When considering the importation ~~or transit~~ of a commodity from an *exporting country, zone or compartment* not declared free of TS ~~of a commodity or from~~ a species not covered in Article 9.4.2. but which could reasonably be expected to pose a risk of transmission ~~be a potential mechanical vector~~ for TSV, ~~the~~ *Competent Authorities* should conduct a *risk analysis* in accordance with the recommendations in the *Aquatic Code*. The *exporting country* should be informed of the outcome of this assessment.

[...]

Article 9.4.9.

**Importation of live aquatic animals and aquatic animal products for processing for human consumption from a country, zone or compartment not declared free from Taura syndrome**

When importing, for processing for human consumption, live *aquatic animals* and aquatic animal products of the species referred to in Article 9.4.2. from a country, *zone* or *compartment* not declared free from TS, the *Competent Authority* of the *importing country* should assess the *risk* and, if justified, require that:

1. the consignment ~~be~~ is delivered directly to and held in *quarantine* or *containment* facilities ~~isolation until for processing and/or consumption;~~ to one of the products referred to in point 1 of Article 9.4.3., or products described in point 1 of Article 9.4.11., or other products authorised by the Competent Authority, and
2. all effluent, ~~dead aquatic animals~~ and waste materials from the processing ~~be~~ are treated in a manner that ensures inactivation of TSV or is disposed in a manner that prevents contact of waste with susceptible species.

For these commodities ~~OIE~~ Members may wish to consider introducing internal measures to address the risks associated with the ~~prevent such commodities~~ being used for any purpose other than for human consumption.

~~This Article does not apply to commodities listed in point 1 of Article 9.4.3.~~

[...]

Article 9.4.11.

**Importation of live aquatic animals and aquatic animal products for retail trade for human consumption from a country, zone or compartment not declared free from Taura syndrome**

1. Competent Authorities should not require any TS related conditions, regardless of the TS status of the exporting country, zone or compartment when authorising the importation or transit of the following commodities which have been prepared and packaged for retail trade and complying with Article 5.3.2.:
  - (i) frozen, peeled shrimp (shell off, head off) (under study).

For these commodities Members may wish to consider introducing internal measures to address the risks associated with the commodity being used for any purpose other than for human consumption.

2. When importing live aquatic animals or aquatic animal products, other than those referred to in point 1 above, of the species referred to in Article 9.4.2. from a country, *zone* or *compartment* not declared free from TS, the *Competent Authority* of the *importing country* should assess the *risk* and apply appropriate *risk mitigation* measures.

~~This Article does not apply to commodities listed in point 1 of Article 9.4.3.~~

-----  
- text deleted

## COMMODITY ASSESSMENTS

### PART I:

#### Taura syndrome (TS) assessments using amended Criteria in Article 5.3.1. (refer to Annex VIII)

Commodities that have been assessed are those currently in the *Aquatic Code* (Article 9.4.3. point 1a) and that are proposed for inclusion in the amended Article 9.4.3. for TS.

'a) For the species referred to in Article 9.4.2. intended for any purpose:

- i) commodities treated in a manner that inactivates the disease agent e.g. boiled or canned or pasteurised products and some ready-to-eat meals; and crustacean oil and crustacean meal intended for use in feed;
- ii) chemically extracted chitin;
- iii) crustacean products made non-infectious through processing as dry feed (e.g. pelleted or extruded feed).'

'Crustacean products made non infectious through processing as dry feed (e.g. pelleted or extruded feed)' and 'some ready-to-eat meals' are currently listed in Article 9.4.3. However, these products are poorly defined and therefore no assessment can be performed. Therefore, it is proposed to delete these products from Article 9.4.3. point 1.

Susceptible species currently listed are Pacific white shrimp or whiteleg shrimp (*Penaeus vannamei*), blue shrimp (*P. stylirostris*), northern white shrimp (*P. setiferus*), southern white shrimp (*P. schmitti*), greasyback prawn (*Metapenaeus ensis*) and giant tiger prawn (*P. monodon*).

#### Assessment for: Crustacean meal ~~intended for use in feed~~

Commodity under consideration		Crustacean meal <del>intended for use in feed</del>	
Criteria 5.3.1.		Assessment	
1.	<b>Absence of disease agent in the traded commodity:</b>		
1a.	<i>There is strong evidence that the disease agent is not present in the tissues from which the commodity is derived</i>	Virus is present in cuticular epithelium, ectodermal and mesodermal tissues. All these tissues may be used in the commodity.	No
AND			
1b.	<i>The water (including ice) used to process or transport the commodity is not contaminated with the disease agent and the processing prevents cross contamination of the commodity to be traded</i>	Water is used in the processing but the product undergoes a drying process	NA
OR			
2.	<b>Even if the disease agent is present in, or contaminates in the tissues from which the commodity is derived, the treatment or processing to produce the commodity to be traded inactivates the disease agent:</b>		
2a.	<i>Physical (e.g. temperature, drying, smoking)</i>	The process involves cooking, usually boiling at least 100°C for 3 minutes; a drying step of between 115-138°C (Velez 1991). Although there is no specific information about inactivation of TSV, another picornavirus (FMDV) is inactivated at 70°C for 30 minutes ( <i>Terrestrial Code</i> , 2009).	

Annex XXV (contd)Annex VI (contd)

<b>Commodity under consideration</b>		<b>Crustacean meal intended for use in food</b>	
<b>Criteria 5.3.1.</b>		<b>Assessment</b>	
AND/OR			
2b.	Chemical (e.g. iodine, pH, salt, smoke)		
AND/OR			
2c.	Biological (e.g. fermentation).		
Conclusion	TSV is highly unlikely to survive this process and <b>crustacean meal</b> is therefore eligible for inclusion in Article 9.4.3. point 1.		

**Assessment for: crustacean oil**

<b>Commodity under consideration</b>		<b>crustacean oil</b>	
<b>Criteria 5.3.1.</b>		<b>Assessment</b>	
1.	<b>Absence of disease agent in the traded commodity:</b>		
1a.	<i>There is strong evidence that the disease agent is not present in the tissues from which the commodity is derived</i>	Virus is present in cuticular epithelium, ectodermal and mesodermal tissues. All these tissues may be used in the commodity.	No
AND			
1b.	<i>The water (including ice) used to process or transport the commodity is not contaminated with the disease agent and the processing prevents cross contamination of the commodity to be traded</i>	Water is used to process the product but the water is potable and the final product is sealed.	NA
OR			
2.	<b>Even if the disease agent is present in, or contaminates in the tissues from which the commodity is derived, the treatment or processing to produce the commodity to be traded inactivates the disease agent:</b>		
2a.	<i>Physical (e.g. temperature, drying, smoking)</i>	Raw material is cooked (may be pre-heated to 50-60°C before cooking at temperatures of 95-100°C for 15-20 minutes. For energy cost reasons and nutritional content, some processors use 80-85°C for 20 minutes). Cooked material is pressed to produce press liquor and press liquor heated to 90-95°C, which produces oil. Oil is purified with hot water (at 90°C) (FAO, 1986).	
AND/OR			
2b.	Chemical (e.g. iodine, pH, salt, smoke)		
AND/OR			
2c.	Biological (e.g. fermentation).		
Conclusion	TSV is highly unlikely to survive this process and crustacean oil is therefore eligible for inclusion in Article 9.4.3. point 1.		



Annex XXV (contd)Annex VI (contd)**Assessment for: Chemically extracted chitin**

Commodity under consideration		Chemically extracted chitin	
Criteria 5.3.1.		Assessment	
1.	<b>Absence of disease agent in the traded commodity:</b>		
1a.	<i>There is strong evidence that the disease agent is not present in the tissues from which the commodity is derived</i>	Virus is present in cuticular epithelium. This tissue is used in the commodity.	No
AND			
1b.	<i>The water (including ice) used to process or transport the commodity is not contaminated with the disease agent and the processing prevents cross contamination of the commodity to be traded</i>	Water is used in the processing but given the chemicals used it is unlikely water would remain contaminated.	NA
OR			
2.	<b>Even if the disease agent is present in, or contaminates in the tissues from which the commodity is derived, the treatment or processing to produce the commodity to be traded inactivates the disease agent:</b>		
2a.	<i>Physical (e.g. temperature, drying, smoking)</i>		
AND/OR			
2b.	<i>Chemical (e.g. iodine, pH, salt, smoke)</i>	Hydrochloric acid is used in the processing and involves heating at 60-70°C for a few hours (Gagné, 1993). Although there is no specific information about inactivation of TSV, another picornavirus (FMD Virus) is inactivated at 70°C for 30 minutes ( <i>Terrestrial Code</i> , 2009).	
AND/OR			
2c.	<i>Biological (e.g. fermentation).</i>		
Conclusion	TSV is highly unlikely to survive this process and chemically extracted chitin is therefore eligible for inclusion in Article 9.4.3. point 1.		

Annex XXV (contd)Annex VI (contd)**Assessment for: pasteurised crustacean products**

<b>Commodity under consideration</b>		<b>Pasteurised crustacean products</b>	
<b>Criteria 5.3.1.</b>		<b>Assessment</b>	
<b>1.</b>	<b>Absence of disease agent in the traded commodity:</b>		
1a.	<i>There is strong evidence that the disease agent is not present in the tissues from which the commodity is derived</i>	Meat contains TSV.	No
<b>AND</b>			
1b.	<i>The water (including ice) used to process or transport the commodity is not contaminated with the disease agent and the processing prevents cross contamination of the commodity to be traded</i>		NA
<b>OR</b>			
<b>2.</b>	<b>Even if the disease agent is present in, or contaminates in the tissues from which the commodity is derived, the treatment or processing to produce the commodity to be traded inactivates the disease agent:</b>		
2a.	<i>Physical (e.g. temperature, drying, smoking)</i>	Heat treatment of 63°C for 30 minutes or equivalent (e.g. 68°C for 3 minutes). Although there is no specific information about inactivation of TSV, another picornavirus (FMDV) is inactivated at 70°C for 30 minutes ( <i>Terrestrial Code</i> , 2009).	
<b>AND/OR</b>			
2b.	<i>Chemical (e.g. iodine, pH, salt, smoke)</i>		
<b>AND/OR</b>			
2c.	<i>Biological (e.g. fermentation).</i>		
<b>Conclusion</b>	There is uncertainty about the inactivation of TSV with heat treatment associated with pasteurisation. Therefore pasteurised products are currently not eligible for inclusion in Article 9.4.3. point 1. Further information is needed.		

Annex XXV (contd)Annex VI (contd)**Assessment for: canned crustacean products**

<b>Commodity under consideration</b>		<b>Canned crustacean products</b>	
<b>Criteria 5.3.1.</b>		<b>Assessment</b>	
1.	<b>Absence of disease agent in the traded commodity:</b>		
1a.	<i>There is strong evidence that the disease agent is not present in the tissues from which the commodity is derived</i>	Meat contains TSV.	No
AND			
1b.	<i>The water (including ice) used to process or transport the commodity is not contaminated with the disease agent and the processing prevents cross contamination of the commodity to be traded</i>	Water is used to process the product but the water is potable and the final product is sealed.	NA
OR			
2.	<b>Even if the disease agent is present in, or contaminates in the tissues from which the commodity is derived, the treatment or processing to produce the commodity to be traded inactivates the disease agent:</b>		
2a.	<i>Physical (e.g. temperature, drying, smoking)</i>	Heat treatment is 121°C for 3.6 minutes or equivalent (e.g. 111°C for 36 minutes) (Ababouch, 1999, 2002). Although there is no specific information about inactivation of TSV, another picornavirus (FMDV) is inactivated at 70°C for 30 minutes (Terrestrial Code, 2009).	
AND/OR			
2b.	<i>Chemical (e.g. iodine, pH, salt, smoke)</i>		
AND/OR			
2c.	<i>Biological (e.g. fermentation).</i>		
Conclusion	TSV is highly unlikely to survive this process <i>and canned crustacean products</i> are therefore eligible for inclusion in Article 9.4.3. point 1.		

Annex XXV (contd)Annex VI (contd)**Assessment for: Boiled Cooked crustacean products**

**NOTE:** The assessment for the listed commodity in the *Aquatic Code*: ‘boiled’ does not describe a traded commodity. Therefore, this assessment has been changed to ‘cooked’ which better describes the traded commodity.

Commodity under consideration		<u>Boiled Cooked</u> crustacean products	
Criteria 5.3.1.		Assessment	
1.	<b>Absence of disease agent in the traded commodity:</b>		
1a.	<i>There is strong evidence that the disease agent is not present in the tissues from which the commodity is derived</i>	Meat contains TSV	No
<b>AND</b>			
1b.	<i>The water (including ice) used to process or transport the commodity is not contaminated with the disease agent and the processing prevents cross contamination of the commodity to be traded</i>		NA
<b>OR</b>			
2.	<b>Even if the disease agent is present in, or contaminates in the tissues from which the commodity is derived, the treatment or processing to produce the commodity to be traded inactivates the disease agent:</b>		
2a.	<i>Physical (e.g. temperature, drying, smoking)</i>	Product is heat treated at 100°C for a minimum of 3 minutes (Ababouch, 1999, 2002). Product is then dried or frozen. Although there is no specific information about inactivation of TSV, it is believed that the processing does inactivate TSV.	
<b>AND/OR</b>			
2b.	<i>Chemical (e.g. iodine, pH, salt, smoke)</i>		
<b>AND/OR</b>			
2c.	<i>Biological (e.g. fermentation).</i>		
Conclusion	TSV is unlikely to survive this process and cooked crustacean products are therefore eligible for inclusion in Article 9.4.3. point 1.		

**REFERENCES**

ABABOUCHE, L. (1999). Heat treatment of foods. Spoilage problems associated with canning. pp 1016-1023. R. Robinson, C. Blatt and P. Patel (editors). Encyclopaedia in food Microbiology. Academic press Limited. London. U.K.

ABABOUCHE L. (2002). HACCP in the fish canning industry. In Safety and quality issues in fish processing (Editor. H. A Bremner). Woodhead Publishing Limited. Cambridge. England, 31–53

FOOD AND AGRICULTURE ORGANIZATION OF THE UNITED NATIONS, (1986). The production of fishmeal and oil, FAO Fisheries Technical Papers T142, 63 pp.

GAGNÉ (1993). Production of chitin and chitosan from crustacean waste and their use as a food processing aid. Masters thesis, McGill University, Montreal. 1993. National Library of Canada. Ottawa Ontario, Canada.

TERRESTRIAL ANIMAL HEALTH CODE (2009). OIE.

VELEZ S.A., ALLEN J.C., KEERY C.M. & ADKINSON R.W. (1991). Evaluation of crab and crawfish waste meals as protein sources for growing dairy heifers. *J. Dairy Sci.*, 74(1), 234–242.

Annex XXV (contd)Annex VI (contd)**PART II:****Taura syndrome (TS) assessments using amended Criteria in Article 5.3.2.** (refer to Annex VIII)

No commodities are currently listed in the *Aquatic Code* (Article 9.4.3. point 1b) as this point is ‘under study’.

However, the *ad hoc* Group assessed a number of commonly traded crustacean products for human consumption that are proposed for inclusion in the amended Article 9.4.11. for TS.

Susceptible species currently listed are Pacific white shrimp or whiteleg shrimp (*Penaeus vannamei*), blue shrimp (*P. stylirostris*), northern white shrimp (*P. setiferus*), southern white shrimp (*P. schmitti*), greasyback prawn (*Metapenaeus ensis*) and giant tiger prawn (*P. monodon*).

**Assessment for: frozen, shell on, head on shrimp**

<b>Commodity under consideration</b>		<b>Frozen, shell on, head on shrimp</b>	
<b>Criteria 5.3.2.</b>		<b>Assessment</b>	
1.	<i>the aquatic animal product is prepared and packaged for direct retail trade for human consumption</i>	It is part of commodity definition.	Y e s
AND EITHER			
2.	<i>It includes only a small amount of waste tissues</i>	Waste includes shell, cephalothorax, legs.	N o
OR			
3.	<i>the disease agent is not normally found in the waste tissues</i>	Exoskeleton and cephalothorax contains the virus. Freezing and cold storage for normal periods will not eliminate the virus (Brock et al., 1997; Lightner 1995).	N o
<b>Conclusion</b>	Frozen, shell on, head on shrimp that are prepared and packaged for retail trade for human consumption may produce amounts of wastes that cannot be considered small; the disease agent may be found in the waste. Therefore, this product is not considered eligible for inclusion in the proposed Article 9.4.11. for Taura syndrome.		

Annex XXV (contd)Annex VI (contd)**Assessment for: frozen, peeled shrimp (shell off, head off)**

<b>Commodity under consideration</b>		<b>frozen, peeled shrimp (shell off, head off)</b>	
<b>Criteria 5.3.2.</b>		<b>Assessment</b>	
1.	<i>The aquatic animal product is prepared and packaged for direct retail trade for human consumption</i>	It is part of commodity definition.	Y e s
<i>AND EITHER</i>			
2.	<i>It includes only a small amount of waste tissues</i>	There are no waste tissues as the entire product is consumed.	Y e s
<i>OR</i>			
3.	<i>The disease agent is not normally found in the waste tissues</i>		
<b>Conclusion</b>	Frozen, peeled shrimp (shell off, head off) that are prepared and packaged for retail trade for human consumption do not produce waste; Therefore, this product is considered to be eligible for inclusion in the proposed Article 9.4.11. for Taura syndrome.  As there is no waste, this product is considered to be eligible for inclusion in the proposed Article 9.X.11. for all crustacean disease chapters.		

**REFERENCES**

BROCK J.A., GOSE R.B., LIGHTNER D.V. & HASSON K.W. (1997). Recent developments and an overview of Taura syndrome of farmed shrimp in the Americas. In: Flegel TW, Hopkins IH (eds) Disease in Asian aquaculture 111. Fish Health Section Asian Fisheries Society, Manila, 275-283

LIGHTNER D.V. (1995). Taura syndrome: an economically important viral disease impacting the shrimp farming industries of the Americas including the United States. Proceedings of the 99th Annual Meeting US Animal Health Association, Reno, Nevada, USA, 36-52.

**Including:**

Amended ARTICLES 11.2.3; 11.2.9; 11.2.11.

Commodity assessments for Articles 11.2.3. and 11.2.11.

## CHAPTER 11.2.

INFECTION WITH *BONAMIA OSTREAE*

[...]

Article 11.2.3.

**Commodities Importation or transit of aquatic animal products for any purpose regardless of the *B. ostreae* status of the exporting country, zone or compartment**

1. ~~When authorising the importation or transit of the following commodities, the Competent Authorities should not require any *B. ostreae* related conditions, regardless of the *B. ostreae* status of the exporting country, zone or compartment when authorising the importation or transit of the following commodities from the species referred to in Article 11.2.2. intended for any purpose and complying with Article 5.3.1.:~~
  - a) ~~From the species referred to in Article 11.2.2. intended for any purpose:~~
    - ~~i) commodities treated in a manner that inactivates the disease agent e.g. canned or~~
    - ~~ii) pasteurised products] (under study)~~
    - ii) ~~biological samples preserved for diagnostic applications in such a manner as to inactivate the disease agent.~~
  - b) ~~The following commodities destined for human consumption from the species referred to in Article 11.2.2. which have been prepared and packaged for direct retail trade:~~
    - i) ~~off the shell (chilled or frozen);~~
    - ii) ~~half shell (chilled).~~
  - e) ~~All commodities from *Crasso streagigas*, *C. virginica*, *Ruditapes decussatus*, *R. philippinarum*, *Mytilus galloprovincialis* and *M. edulis*, including the live aquatic animal.~~

~~For the commodities referred to in point 1b), OIE Members may wish to consider introducing internal measures to address the risks associated with the commodity being used for any purpose other than for human consumption.~~

Annex XXV (contd)Annex VII (contd)

2. When authorising the importation or transit of *commodities* of a species referred to in Article 11.1.2., other than those referred to in point 1 of Article 11.2.3., ~~the~~ *Competent Authorities* should require the conditions prescribed in Articles 11.2.7. to 11.2.11. relevant to the *B. ostreae* status of the *exporting country, zone or compartment*.
3. When considering the importation ~~or transit of a commodity~~ from an *exporting country, zone or compartment* not declared free of infection with *B. ostreae* ~~of a commodity from bivalve~~ a species not covered in Article 11.2.2. ~~or in point 1c) of Article 11.2.3.~~ but which could reasonably be expected to pose a risk of transmission ~~be a potential mechanical vector~~ for *B. ostreae*, ~~the~~ *Competent Authorities* should conduct a *risk analysis* in accordance with the recommendations in the *Aquatic Code*. The *exporting country* should be informed of the outcome of this assessment.

[...]

Article 11.2.9.

**Importation of live aquatic animals and aquatic animal products for processing for human consumption from a country, zone or compartment not declared free from *B. ostreae***

When importing, for processing for human consumption, live *aquatic animals* and aquatic animal products of the species referred to in Article 11.2.2. from a country, *zone or compartment* not declared free from *B. ostreae*, the *Competent Authority* of the *importing country* should assess the *risk* and, if justified, require that:

1. the consignment ~~be~~ is delivered directly to and held in *quarantine or containment* facilities ~~until~~ for processing and/or consumption to one of the products referred to in point 1 of Article 11.2.3., or products described in point 1 of Article 11.2.11., or other products authorised by the *Competent Authority* and
2. all effluent and waste material from the processing are treated in a manner that ensures inactivation of *B. ostreae* or is disposed in a manner that prevents contact of waste with susceptible species.

For these *commodities* Members may wish to consider introducing internal measures to address the *risks* associated with the *commodity* being used for any purpose other than for human consumption.

This Article does not apply to *commodities* referred to in point 1 of Article 10.1.3.

[...]

Article 11.2.11.

**Importation of live aquatic animals and aquatic animal products for retail trade for human consumption from a country, zone or compartment not declared free from *B. ostreae***

1. *Competent Authorities* should not require any *B. ostreae* related conditions, regardless of the *B. ostreae* status of the *exporting country, zone or compartment* when authorising the importation or transit of the following *commodities* which have been prepared and packaged for retail trade and complying with Article 5.3.2.:



Annex XXV (contd)Annex VII (contd)

ii) ~~off the shell~~ oyster meat (chilled or frozen);

ii) ~~half-shell (chilled or frozen).~~ (under study)

For these commodities Members may wish to consider introducing internal measures to address the risks associated with the commodity being used for any purpose other than for human consumption.

2. When importing live aquatic animals or aquatic animal products, other than those referred to in point 1 above, of the species referred to in Article 11.2.2. from a country, zone or compartment not declared free from *B. ostreae*, the Competent Authority of the importing country should assess the risk and apply appropriate risk mitigation measures.

~~This Article does not apply to commodities referred to in point 1 of Article 10.1.3.~~

-----  
- text deleted

## COMMODITY ASSESSMENTS

### PART I:

**Infection with *Bonamia ostreae* assessments using amended Criteria in Article 5.3.1.**  
(refer to Annex VIII)

Commodities that have been assessed are those currently in the *Aquatic Code* (Article 11.2.3. point 1a) and that are proposed for inclusion in the amended Article 11.2.3. for *B. ostreae*.

'a) For the species referred to in Article 9.4.2. intended for any purpose:

i) commodities treated in a manner that inactivates the disease agent e.g. canned or pasteurised products.'

Susceptible species currently listed are: European flat oyster (*Ostrea edulis*), Australian mud oyster (*O. angasi*), Argentinean flat oyster (*O. puelchana*), Chilean flat oyster (*O. chilensis*), Asiatic oyster (*O. denselammellosa*) and Suminoe oyster (*Crassostrea ariakensis*).

The *ad hoc* Group did not perform the assessment for canned or pasteurised products as it is believed the susceptible species (flat oysters) are not prepared and internationally traded under this form.

Annex XXV (contd)Annex VII (contd)**PART II:****Infection with *Bonamia ostreae* (*B. ostreae*) assessments using amended Criteria in Article 5.3.2. (refer to Annex VIII)**

Commodities that have been assessed are those currently in the *Aquatic Code* (Article 11.2.3. point 1b) that are proposed for inclusion in the amended Article 11.2.11. for *B. ostreae*:

*'The following commodities destined for human consumption from the species referred to in Article 11.2.2. which have been prepared and packaged for direct retail trade:*

1. *off the shell (chilled or frozen);*
2. *half-shell (chilled).'*

Susceptible species currently listed are: European flat oyster (*Ostrea edulis*), Australian mud oyster (*O. angasi*), Argentinean flat oyster (*O. puelchana*), Chilean flat oyster (*O. chilensis*), Asiatic oyster (*O. denselammellosa*) and Suminoe oyster (*Crassostrea ariakensis*).

**Assessment for: ~~off the shell~~ oyster meat (chilled or frozen)**

Commodity under consideration		<del>off the shell</del> Oyster meat (chilled or frozen)	
Criteria 5.3.2.		Assessment	
1.	<i>the aquatic animal product is prepared and packaged for direct retail trade for human consumption</i>	It is part of commodity definition	Y e s
AND EITHER			
2.	<i>It includes only a small amount of waste tissues</i>	There are no waste tissues as the entire product is consumed	Y e s
OR			
3.	<i>the disease agent is not normally found in the waste tissues</i>		
<b>Conclusion</b>	Oyster meat (chilled or frozen) that are prepared and packaged for retail trade for human consumption do not produce waste; Therefore, this product is considered to be eligible for inclusion in the proposed Article 11.2.11. for <i>B. ostreae</i> . As there is no waste, this product is considered to be eligible for inclusion in the proposed Article 11.X.11. for all mollusc disease chapters.		

**Assessment for: half-shell (chilled or frozen)**

Commodity under consideration		Half-shell (chilled <u>or</u> frozen)	
Criteria 5.3.2.		Assessment	
1.	<i>the aquatic animal product is prepared and packaged for direct retail trade for human consumption</i>	It is part of commodity definition	Y e s
AND EITHER			
2.	<i>It includes only a small amount of waste tissues</i>	Half the shell with piece of adductor muscle attached.	N o
OR			
3.	<i>the disease agent is not normally found in the waste tissues</i>	Protozoa unlikely to be present in the adductor muscle until late in the development of the disease and therefore would be rejected for human consumption. Ice is potable water, therefore likelihood of pathogen survival is negligible.	Y e s
<b>Conclusion</b>	Half shell oysters (chilled or frozen) that are prepared and packaged for retail trade for human consumption may produce amounts of wastes that cannot be considered small; the disease agent is unlikely to be found in the waste tissues. Therefore, this product is considered to be eligible for inclusion in the proposed Article 11.2.11. for <i>B. ostreae</i> .		

## CHAPTER 5.3.

## CRITERIA TO ASSESS THE SAFETY OF AQUATIC ANIMAL COMMODITIES

Green highlighted text shows changes required to align Articles with the proposed changes to Articles X.X.3, X.X.9, X.X.12.

## Article 5.3.1.

### Criteria to assess the safety of aquatic animal products ~~commodities~~ irrespective regardless of ~~country~~ disease status

In all *disease* chapters, point 1a) of Article X.X.3. lists ~~commodities~~ aquatic animal products that can be traded irrespective regardless of ~~country~~ disease status. The criteria for inclusion of ~~commodities~~ aquatic animal products in point 1a) of Article X.X.3. are based on the absence of the *disease agent* in the traded ~~commodity~~ aquatic animal product or inactivation of the *disease agent* by treatment or processing.

The assessment of the safety of the ~~commodity~~ aquatic animal product using the criteria relating to treatment or processing can only be undertaken where treatments or processing are well defined. It may not be necessary to provide details of the entire treatment or process undertaken. However, the steps considered critical in the inactivation of the *disease agent* of concern should be detailed.

It is assumed that treatment or processing (i) uses standardised protocols, which include the steps considered critical in the inactivation of the *disease agent* of concern; (ii) is conducted according to Good Manufacturing Practices; and (iii) that any other steps in the treatment, processing and subsequent handling of the ~~commodity~~ aquatic animal product do not jeopardise the safety of the traded ~~commodity~~ aquatic animal product.

For an ~~an~~ ~~commodity~~ aquatic animal product to be considered safe for *international trade* under the provisions of point 1a) of Article X.X.3., it should comply with the following criteria:

1. Absence of *disease agent* in the traded ~~commodity~~ aquatic animal product:
  - a) There is strong evidence that the *disease agent* is not present in the tissues from which the ~~commodity~~ aquatic animal product is derived.

AND

  - b) The water (including ice) used to process or transport the ~~commodity~~ aquatic animal product is not contaminated with the *disease agent* and the processing prevents cross contamination of the ~~commodity~~ aquatic animal product to be traded.

OR

Annex XXV (contd)Annex VIII (contd)

2. Even if the *disease agent* is present in, or contaminates the tissues from which the ~~commodity~~ aquatic animal product is derived, the treatment or processing to produce the ~~commodity~~ aquatic animal product to be traded inactivates the *disease agent*:
- a) physical (e.g. temperature, drying, smoking);
- AND/OR
- b) chemical (e.g. iodine, pH, salt, smoke);
- AND/OR
- c) biological (e.g. fermentation).

## Article 5.3.2.

**Criteria to assess the safety of live aquatic animals or aquatic animal products destined for retail trade for human consumption from a country, zone or compartment not declared free of a irrespective of country disease status**

In all *disease* chapters, point 1 ~~b)~~ of Article X.X. ~~123~~. ~~(fish disease chapters) and: Article X.X.X.11. (mollusc and crustacean disease chapters)~~ lists live aquatic animals or aquatic animal products for retail trade destined for human consumption. The criteria for inclusion of live aquatic animals or aquatic animal products in point 1 ~~b)~~ of Article X.X. ~~123~~, include consideration of the form and presentation of the product, the expected volume of waste tissues generated by the consumer and the likely quantity of viable *disease agent* in the waste.

For the purpose of this criterion retail means the selling or provision of live aquatic animals or aquatic animal products directly to the consumer with the intended purpose of human consumption. The retail pathway may also include wholesale distribution of the products provided they are not further processed by the wholesale distributor or the retailer, i.e. are not subjected to actions such as gutting, cleaning, filleting, freezing, thawing, cooking, unpacking, packing or repackaging.

It is assumed that:

- i) the live aquatic animals or aquatic animal products ~~is~~ are used for human consumption only;
- ii) waste may not always be handled in an appropriate manner that mitigates the introduction of the *disease agent*. The level of risk is related to the waste disposal practices in each Member's country or territory;
- iii) treatment or processing prior to importation ~~(i) uses standardised protocols, which include the steps considered critical in the inactivation of the *disease agent* of concern; and (ii) is conducted according to Good Manufacturing Practices; and (iii)~~

Annex XXV (contd)

Annex VIII (contd)

- iv) ~~that~~ any other steps in the treatment, processing and subsequent handling of the live aquatic animals or aquatic animal products prior to importation do not jeopardise the safety of the traded live aquatic animals or aquatic animal products

For live aquatic animals or aquatic animal products to be considered ~~safe~~ for *international trade* under the provisions of point 1-b) of Article X.X.123. (fish disease chapters); Article X.X.X.11. (mollusc and crustacean disease chapters), it should comply with the following criteria:

1. the live aquatic animals or aquatic animal product is prepared and packaged for retail trade for human consumption; AND

EITHER

2. it includes only a small amount of waste tissues;

OR

3. ~~viable disease agent is unlikely to be present in the waste tissues, because:~~

- a) ~~the disease agent is not normally found in the waste tissues;~~

OR

- b) ~~the disease agent may be present in the waste tissues but the processing prior to importation involves processes known to inactivate and/or reduce the load of disease agent:~~

- i) ~~physical (e.g. temperature, drying, smoking);~~

OR

- ii) ~~chemical (e.g. pH, salt, smoke);~~

OR

- iii) ~~biological (e.g. fermentation).~~

-----  
- text deleted



## Disinfected eggs – new Article

### Article 10.4.X.

#### **Importation of disinfected eggs for aquaculture from a country, zone or compartment not declared free from infectious haematopoietic necrosis**

1. When importing disinfected eggs of the species referred to in Article 10.5.2 for aquaculture from a country, zone or compartment not declared free from IHN, the Competent Authority of the importing country should assess the risk associated with at least:
  - a) the IHN virus status of the water used during the disinfection the eggs
  - b) the level of infection with IHN virus in broodstock (ovarian fluid and milt); and
  - c) the temperature and pH of the water used for disinfection.
2. If importation is justified, the Competent Authority of the importing country should apply the following risk mitigation measures:
  - a) the eggs should be disinfected prior to importing, according to the methods described in the Chapter 1.1.3. of the Aquatic Manual or those specified by the Competent Authority of the importing country; and
  - b) between disinfection and the import, eggs must be kept in specific pathogen free water.
3. When importing disinfected eggs of the species referred to in Article 10.4.2 for aquaculture from a country, zone or compartment not declared free from IHN, the Competent Authority of the importing country should require an international aquatic animal health certificate issued by the Competent Authority of the exporting country or a certified official approved by the importing country attesting that the procedures described Article 10.4.X. point 2 have been fulfilled.

### Article 10.5.X.

#### **Importation of disinfected eggs for aquaculture from a country, zone or compartment not declared free from infectious salmon anaemia**

1. When importing disinfected eggs of the species referred to in Article 10.5.2 for aquaculture from a country, zone or compartment not declared free from ISA, the Competent Authority of the importing country should assess the risk associated with at least:
  - a) the ISA virus status of the water used during the disinfection the eggs
  - b) the level of infection with ISA virus in broodstock (ovarian fluid and milt); and
  - c) the temperature and pH of the water used for disinfection.

Annex XXV (contd)Annex IX (contd)

2. If importation is justified, the *Competent Authority* of the *importing country* should apply the following *risk mitigation measures*:
  - a) the *eggs* should be disinfected prior to importing, according to the methods described in the Chapter 1.1.3. of the *Aquatic Manual* or those specified by the *Competent Authority* of the *importing country*, and
  - b) between disinfection and the import, *eggs* must be kept in specific pathogen free water.
  
3. When importing disinfected *eggs* of the species referred to in Article 10.5.2 for *aquaculture* from a *country, zone or compartment* not declared free from ISA, the *Competent Authority* of the *importing country* should require an *international aquatic animal health certificate* issued by the *Competent Authority* of the *exporting country* or a *certified official* approved by the *importing country* attesting that the procedures described Article 10.5.X. point 2 have been fulfilled.

Article 10.9.X**Importation of disinfected eggs for *aquaculture* from a *country, zone or compartment* not declared free from viral haemorrhagic septicaemia**

1. When importing disinfected *eggs* of the species referred to in Article 10.9.2 for *aquaculture* from a *country, zone or compartment* not declared free from VHS, the *Competent Authority* of the *importing country* should assess the *risk* associated with at least:
  - a) the VHS virus status of the water used during the disinfection the *eggs*;
  - b) the level of *infection* with VHS virus in broodstock (ovarian fluid and milt); and
  - c) the temperature and pH of the water used for *disinfection*.



Annex XXV (contd)

Annex IX (contd)

2. If importation is justified, the *Competent Authority* of the *importing country* should apply the following *risk mitigation measures*:
- a) the *eggs* should be disinfected prior to importing, according to the methods described in the Chapter 1.1.3. of the *Aquatic Manual* or those specified by the *Competent Authority* of the *importing country*, and
- b) between *disinfection* and the import, *eggs* must be kept in specific pathogen free water.
3. When importing disinfected *eggs* of the species referred to in Article 10.9.2 for *aquaculture* from a country, zone or *compartment* not declared free from VHS, the *Competent Authority* of the *importing country* should require an *international aquatic animal health certificate* issued by the *Competent Authority* of the *exporting country* or a *certified official* approved by the *importing country* attesting that the procedures described Article 10.9.X. point 2 have been fulfilled.
-



Original: English  
September 2009

**REPORT OF THE MEETING OF THE OIE AD HOC GROUP ON THE  
OIE LIST OF AQUATIC ANIMAL DISEASES  
- CRUSTACEAN TEAM -  
FOR THE OIE AQUATIC ANIMAL HEALTH CODE  
Electronic Working Group: July – September 2009**

The OIE *ad hoc* Group on the OIE List of Aquatic Animal Diseases - Crustacean Team for the OIE *Aquatic Animal Health Code* (hereinafter called the *ad hoc* Group) was convened at the recommendation of the Aquatic Animal Health Standards Commission and met electronically during July to September 2009.

The members of the OIE *ad hoc* Group are listed in [Annex I](#) and the adopted agenda is provided in [Annex II](#).

Below are agenda items, a summary of the *ad hoc* Group deliberations on each item, and the *ad hoc* Group recommendations to the OIE Aquatic Animal Health Standards Commission (hereinafter called the Aquatic Animals Commission).

**Agenda Items:**

**Item 1.** *‘Review and comment on Canada’s recommendation that Necrotizing Hepatopancreatitis (NHP) disease of penaeid shrimp remain ‘under study’ while additional information on its global distribution, diagnostic methods, its non-penaeid host range and modes of transmission are determined.’*

The *ad hoc* Group reviewed various documents and publications on NHP disease, as well as its previous assessments relative to the Criteria for listing aquatic animal diseases in Article 1.2.1. of Chapter 1.2. in the *Aquatic Animal Health Code* (hereinafter called the *Aquatic Code*) (refer to Annex XVII of the October 2008 Report of the Aquatic Animals Commission).

The *ad hoc* Group re-assessed NHP disease against the Criteria for listing aquatic animal diseases in Article 1.2.1 of the *Aquatic Code* Chapter 1.2. and agreed that it meets the criteria for full listing (see Table 1 below). The *ad hoc* Group concluded that reported efficacy of antibiotic therapy for NHP disease should not be a consideration when production losses are considered (criteria A.1.) or its potential for international spread (criteria A.6.).

Annex XXVI (contd)

Furthermore, there are a number of publications on diagnostic methods for NHP disease that include traditional histopathology, antibody-based and molecular methods for diagnosis and/or detection of the bacterial agent of NHP disease. Kits for PCR detection of the agent of NHP are commercially available in Asia and the Americas. Hence, the *ad hoc* Group disagrees with the Canadian expert and concluded that the available diagnostic methods for NHP disease meet the listing requirement (criteria A.8.).

**Table 1.** Consensus of the *ad hoc* Group's assessment of Necrotizing hepatopancreatitis (NHP) disease of penaeid shrimp using the criteria in Article 1.2.1 of Chapter 1.2. in the *Aquatic Code*.

Diseases considered by the AHG	Assessment Against the OIE Listing Criteria in the Aquatic Code								AHG conclusion
	1	2	3	4	5	6	7	8	
Necrotizing hepatopancreatitis (NHB-B / bacteria)	+	NA	NA	+	NA	+	+	+	Full listing

NA = not applicable.

**Recommendation:**

NHP disease meets the criteria for full listing and therefore should be listed as an OIE listed disease.

**Item 2.**

*Review whether White Tail Disease (WTD) of Macrobrachium rosenbergii, which was approved for full listing by the International Committee of the OIE in May 2009 due to a procedural error, remain listed or be returned to listing as 'under study'*

The *ad hoc* Group re-assessed WTD against the listing criteria in the *Aquatic Code* Chapter 1.2., Article 1.2.1. According to both published and unpublished reports from industry, WTD has caused major production problems in China, India and most recently in Vietnam. It is apparent that WTD is expanding in its geographic range. This new information about WTD and previous assessments of the disease by the *ad hoc* Group, reaffirm that WTD meets listing criteria A.1., A.4., A.6. A.7. and A.8. (see Table 2 below).

Therefore, the *ad hoc* Group recommends that, despite the procedural error that led to WTD being prematurely listed by the OIE, WTD should remain fully listed. Specific comments of the *ad hoc* Group members are presented in Annex III.

**Table 2.** Consensus of the *ad hoc* Group's assessment of White Tail Disease (WTD) disease of *Macrobrachium rosenbergii* using the criteria in Article 1.2.1 of Chapter 1.2. in the *Aquatic Code*.

Diseases considered by the AHG	Assessment Against the OIE Listing Criteria in the Aquatic Code								AHG conclusion
	1	2	3	4	5	6	7	8	
White Tail Disease (WTD / viral)	+	NA	NA	+	NA	+	+	+	Full listing

NA = not applicable.

**Recommendation:**

WTD meets the criteria for full listing and therefore should remain fully listed.



**THE OIE AD HOC GROUP ON AQUATIC ANIMAL DISEASES  
– CRUSTACEAN TEAM –  
FOR THE OIE AQUATIC ANIMAL HEALTH CODE**

**Electronic Working Group: July – September 2009**

—————  
**List of participants**

**MEMBERS OF THE AD HOC GROUP**

---

**Professor Donald V. Lightner**  
(chair person)  
Department of Veterinary Science &  
Microbiology  
University of Arizona  
Tucson, AZ 85721  
UNITED STATES OF AMERICA  
Tel.: + (1-520) 621.84.14  
Fax: + (1-520) 621.48.99  
E-mail: [dvl@u.arizona.edu](mailto:dvl@u.arizona.edu)

**Professor Peter J Walker**  
CSIRO Australia Animal Health  
Laboratory (AAHL)  
5 Portarlington Road, Geelong VIV 3220  
AUSTRALIA  
Tel.: (+61.3) 52.27.50.00  
Fax: (+61.3) 52.27.54.00  
E-mail: [peter.walker@csiro.au](mailto:peter.walker@csiro.au)

**Professor Grace Chu-Fang Lo**  
Department & Institute of Zoology  
National Taiwan University  
1, Sec. 4, Roosevelt Rd.  
TAIPEI, CHINA  
Tel: (+886-2) 23.63.02.31/22.62  
Fax: (+886-2) 23.63.68.37  
E-mail: [gracelow@ntu.edu.tw](mailto:gracelow@ntu.edu.tw)



**THE OIE *AD HOC* GROUP ON AQUATIC ANIMAL DISEASES  
– CRUSTACEAN TEAM –  
FOR THE OIE *AQUATIC ANIMAL HEALTH CODE***

Electronic Working Group: July – September 2009

---

**Adopted Agenda**

1. Review and comment on Canada's recommendation that NHP disease of penaeid shrimp remain 'under study' while additional information on its global distribution, diagnostic methods, its non-penaeid host range and modes of transmission are determined.
  2. Review whether White Tail Disease (caused by the nodavirus, MrNV) of *Macrobrachium rosenbergii*, which was approved for full listing by the International Committee of the OIE in May 2009 due to a procedural error, remain listed or be returned to listing as “under study.”
-





## AQUATIC ANIMALS COMMISSION WORK PLAN FOR 2010/2011

<i>Aquatic Animal Health Code</i>
<ul style="list-style-type: none"> <li>• Ongoing review of the list of diseases</li> <li>• Review emerging diseases</li> </ul>
<ul style="list-style-type: none"> <li>• Prepare text for disease chapters for gaining and regaining freedom for compartments</li> </ul>
<ul style="list-style-type: none"> <li>• Harmonise horizontal chapters with those in the <i>Terrestrial Code</i></li> </ul>
<ul style="list-style-type: none"> <li>• Develop disease specific surveillance model chapters (1 fish, 1 mollusc, 1 crustacean)</li> </ul>
<ul style="list-style-type: none"> <li>• Finalise new chapter on Handling and disposal of carcasses and wastes of aquatic animals</li> </ul>
<ul style="list-style-type: none"> <li>• Prepare and finalise chapters on welfare for farmed fish (humane killing and disease control)</li> </ul>
<ul style="list-style-type: none"> <li>• Antimicrobial resistance in the field of aquatic animals – contribute to OIE work</li> </ul>
<ul style="list-style-type: none"> <li>• Develop disease chapter for Infection with abalone herpes-like virus</li> </ul>
<ul style="list-style-type: none"> <li>• Develop chapter on Evaluation of Competent Authorities</li> </ul>
<ul style="list-style-type: none"> <li>• Identify commodities that can be considered safe for trade and be included in the <i>Aquatic Code</i></li> </ul>
<ul style="list-style-type: none"> <li>• Guidance on considering species as susceptible to diseases</li> </ul>
<ul style="list-style-type: none"> <li>• Finalise Articles for disinfection of salmonid eggs for relevant disease chapters</li> </ul>
<i>Manual of Diagnostic Tests for Aquatic Animals</i>
<ul style="list-style-type: none"> <li>• Prepare disease chapters for amphibian diseases</li> </ul>
<ul style="list-style-type: none"> <li>• Prepare disease chapter for Infection with abalone herpes-like virus disease</li> </ul>
<i>Meetings</i>
<ul style="list-style-type: none"> <li>• Make presentations on the activities of the Aquatic Animals Commission at the conferences of the OIE Regional Commissions</li> </ul>
<ul style="list-style-type: none"> <li>• Be proactive in presenting the activities of the Aquatic Animals Commission at scientific conferences</li> </ul>
<ul style="list-style-type: none"> <li>• Contribute to the 2<sup>nd</sup> OIE Global Conference on ‘Contribution of Aquatic Animal Health to Global Food Security’</li> </ul>
<ul style="list-style-type: none"> <li>• Contribute to OIE Aquatic Animal Focal Point training workshops</li> </ul>
<i>Other issues</i>
<ul style="list-style-type: none"> <li>• Update Aquatic Animals Commission position paper on pathogen strain differentiation</li> </ul>
<ul style="list-style-type: none"> <li>• Keep the Commission’s web pages up to date</li> </ul>
<ul style="list-style-type: none"> <li>• Consider new candidates for OIE Reference Laboratories for listed diseases</li> </ul>
<ul style="list-style-type: none"> <li>• Provide input into the PVS to ensure its applicability to the evaluation of aquatic animal health systems</li> </ul>
<ul style="list-style-type: none"> <li>• Contribute to FAO/OIE Regional Aquatic Biosecurity Framework Project for Africa</li> </ul>
<ul style="list-style-type: none"> <li>• Provide input into the review of the OIE Handbook on Import Risk Analysis</li> </ul>

---

© **World Organisation for Animal Health (OIE), 2009**

This document has been prepared by specialists convened by the World Organisation for Animal Health (OIE). Pending adoption by the International Committee of the OIE, the views expressed herein can only be construed as those of these specialists.

All OIE publications are protected by international copyright law. Extracts may be copied, reproduced, translated, adapted or published in journals, documents, books, electronic media and any other medium destined for the public, for information, educational or commercial purposes, provided prior written permission has been granted by the OIE.

The designations and denominations employed and the presentation of the material in this publication do not imply the expression of any opinion whatsoever on the part of the OIE concerning the legal status of any country, territory, city or area or of its authorities, or concerning the delimitation of its frontiers and boundaries.

The views expressed in signed articles are solely the responsibility of the authors. The mention of specific companies or products of manufacturers, whether or not these have been patented, does not imply that these have been endorsed or recommended by the OIE in preference to others of a similar nature that are not mentioned.